

Typical Design Criteria

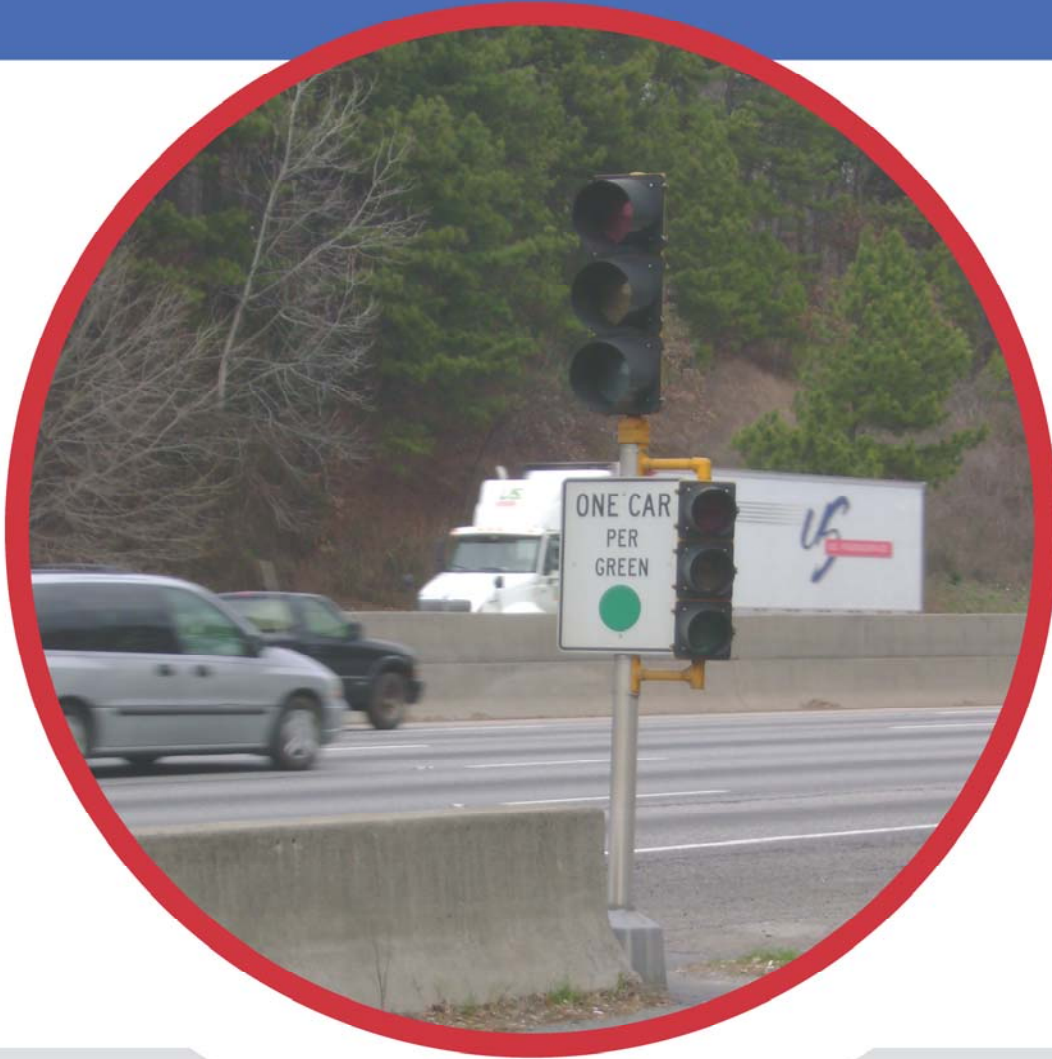

*M-0468 Ramp Metering Feasibility Study for
Cabarrus, Gaston, Iredell and Mecklenburg
Counties*

Notice

This document and its contents have been prepared and are intended solely for the North Carolina Department of Transportation’s (NCDOT) information and use in relation to Ramp Metering Feasibility Study for Cabarrus, Gaston, Iredell and Mecklenburg Counties.

Atkins assumes no responsibility to any other party in respect of, or arising out of, or in connection with this document and/or its contents.

This document has 64 pages including the cover.

Document History

Job number: M-0468			Document Reference: Typical Ramp Metering Design Criteria			
Revision	Purpose description	Originated	Checked	Reviewed	Authorized	Date
2.0	Draft task report	HAB	CJM	JAO	HAB	4/15/16
3.0	QC & NCDOT comments	HAB	JAO	HAB	HAB	5/5/16
5.0	Submitted report	HAB	JAO	HAB	HAB	7/26/16
6.0	Final QC for Final Report	JGO	HAB	HAB	HAB	5/15/17

Client Signoff

Client	NCDOT
Project	Metrolina Ramp Metering Feasibility Study for Cabarrus, Gaston, Iredell, and Mecklenburg Counties
Document title	Typical Design Criteria
Job no.	100047257 (M-0468)
Copy no.	
Document reference	task 7 - final typical design criteria - final 20170515

Table of Contents

Chapter	Page
Introduction	6
1. Site Selection Criteria	7
1.1. General Site Selection Factors.....	7
1.2. Traffic Congestion	7
1.3. Traffic Volumes	8
1.4. Crashes	9
2. Design	10
2.1. Basic Ramp Metering Components.....	10
2.2. Geometric Standards.....	11
2.3. Signalization Design Standards.....	19
2.4. Signing and Pavement Marking Standards	27
3. Operations	32
3.1. Ramp Metering Operations	32
Bibliography	35
Appendices	36
Appendix A. Site Requirements	A-1
Appendix B. Typical Ramp Meter Layouts	B-1
Appendix C. Signal Head and Equipment Layouts	C-1
Appendix D. Ramp and Mainline Detection Layouts	D-1
Appendix E. Typical Ramp Meter Signing Layouts	E-1
Appendix F. Optional Enforcement Features	F-1

List of Tables

Table		Page
Table 1.	AASHTO Stopping Sight Distance.....	15
Table 2.	AASHTO Minimum Acceleration Lengths for Entrance Ramps	16
Table 3.	Queue Distance	16
Table 4.	FHWA Ramp Meter Operation Guidance - Number of Lanes and Release Rate.....	17
Table 5.	Signal Head Placement Requirements.....	21
Table 6.	Calculation of Advance Queue Detector Location	25
Table 7.	Ramp Meter Warning Signs	29
Table 8.	Regulatory Ramp Meter Signs.....	30

List of Figures

Figure	Page
Figure 1: Ideal Criteria for Ramp Metering.....	8
Figure 2: Site Design Process	10
Figure 3: Typical Ramp Meter Site Layout.....	11
Figure 4: Option 1: Ramp Merge Upstream of Gore.....	18
Figure 5: Option 2: Ramp Merge Downstream of Gore	18
Figure 6: Single Point Urban Interchange.....	25
Figure 7: Queue Detection for Single Point Urban Interchange.....	26
Figure 8: Diverging Diamond Interchange	27
Figure B-1: Single Lane Ramp Meter Overview.....	B-2
Figure B-2: Two Lane Ramp Meter Overview	B-3
Figure B-3: Three Lane Ramp Meter Overview	B-4
Figure B-4: Single Lane Ramp Meter with Transit Bypass Overview.....	B-5
Figure B-5: Single Lane Freeway-to-Freeway Ramp Meter Overview	B-6
Figure B-6: Two Lane Freeway-to-Freeway Ramp Meter Overview	B-7
Figure C-1: Single Lane Ramp Meter Signalization and Equipment Layout	C-2
Figure C-2: Single Lane Ramp Meter with Transit Bypass Signalization and Equipment Layout.....	C-3
Figure C-3: Two Lane non-Freeway-to-Freeway Ramp Meter Signalization and Equipment Layout.....	C-4
Figure C-4: Freeway-to-Freeway Ramp Meter Signalization and Equipment Layout	C-5
Figure D-1: Single Lane Ramp Meter Detection	D-2
Figure D-2: Single Lane Ramp Meter with Transit Bypass Detection	D-3
Figure D-3: Mainline Detection	D-4
Figure E-1: Non-Freeway-to-Freeway Ramp Meter Signing and Pavement Markings	E-2
Figure E-2: Single Lane Loop Ramp Meter Signing and Pavement Markings	E-3
Figure E-3: Freeway-to-Freeway Ramp Meter Signing and Pavement Markings	E-4
Figure F-1: Optional Enforcement Features.....	F-2

Introduction

This report presents the typical ramp metering design criteria. It includes site selection criteria, operational strategies, and standards for geometric layout, signalization design, signing, and pavement markings.

Ramp Metering Overview and Benefits

The main objective of ramp metering is to reduce congestion and improve freeway efficiency. Ramp meters are a tool used to manage traffic on freeways by regulating the rate vehicles can enter the freeway—typically one or two vehicles at a time—in order to improve the average speed of all vehicles traveling on the freeway. Ramp meters help balance demand with capacity and reduce flow breakdown on the freeway by preventing large platoons of vehicles from entering the freeway at any given time. By increasing the total number of vehicles accommodated by the freeway, ramp meters also increase efficiency. Although vehicles are briefly delayed at entrance ramp queues, the goal is for this delay to be negated in the overall reduction in travel time.

Ramp meters consist of traffic signals located on freeway entrance ramps that regulate the rate vehicles can access the freeway. The ramp metering rate can be based on historical data or real-time conditions obtained by vehicle detectors. Various methods and algorithms are used in different ramp metering operations based on different system goals. Ramp metering system benefits include the following:

- Safer and smoother merging for vehicles entering freeways
- Reduced congestion
- Increased and steadier flow
- Increased speed
- Decreased delay
- Reduced vehicle emissions
- Improved ramp queue management to prevent spillback onto the crossing roadways
- Reduced rear-end and side-swipe accidents

FHWA's *Manual on Uniform Traffic Control Devices*¹ (*MUTCD*), 2009 Edition, revised 2012 describes ramp metering standards in Chapter 4I: Traffic Control Signals for Freeway Entrance Ramps. The *MUTCD* briefly covers the application, design, and operation of freeway entrance ramp control signals. A detailed analysis of ramp metering practices and design procedure may be found in FHWA's *Ramp Management and Control Handbook*² although the handbook does not constitute a standard, specification, or regulation.

¹ *Manual on Uniform Traffic Control Devices*, Federal Highway Administration, 2009, revised 2012

² *Ramp Management and Control Handbook*, Federal Highway Administration, 2006

1. Site Selection Criteria

1.1. General Site Selection Factors

Suitability of a site for the implementation of ramp metering is dependent on both traffic and the physical characteristics of each facility that would be affected by the system, including the mainline freeway, ramps, ramp connections, and surface streets. The determination of suitability for a ramp metering site includes:

- Identification of existing traffic conditions (speed, volume, etc.).
- Assessment of site versus traffic characteristics.
- Assessment of ramp geometry.

A number of traffic and geometric characteristics dictate if a site is suitable for ramp metering. These characteristics are discussed in the following sections.

1.2. Traffic Congestion

The main purpose of ramp metering is to reduce congestion caused by merging traffic. Ramp metering is most effective when the freeway mainline congestion is caused by merging traffic from the ramp or excessive demand downstream of the merge. Ramp metering has also been proven effective in solving congestion in situations where:

- Merging traffic from ramps disrupts mainline freeway traffic flow.
- Weaving traffic exists due to closely spaced merge and diverge points.
- Ramps fed by signalized intersection on the adjacent arterial network cause large platoons of freeway-bound traffic.
- Ramp volumes overload the merge capacity.
- Ramp volumes are affected by the flow breakdown along the mainline freeway downstream of the ramp.
- Traffic queues on the ramp back up during peak periods.

Before starting the design process, it is essential to have a thorough understanding of all current and planned improvements that can have any impact on volumes through a ramp metering location. Local operations likely to have an impact on the traffic volumes include:

- Changes to adjoining road layout and how they feed traffic onto the ramp.
- Modifications to the entrance ramp.
- Changes to the use of the entrance ramp due to changes in demand.
- Changes to the number of lanes on the freeway.
- Introduction of managed roadway features such as active traffic management applications.
- Infrastructure changes such as communication implementation or new bridge construction.
- Changes to speed limits in the area.

- Impacts of other ramp metering sites and their effect on local traffic.

The implementation plan will consider near-term planned improvements that may directly impact the installation of ramp meters. Depending on the other projects, it may be proposed that certain ramp meter sites be accelerated, postponed, dropped, or included in another project already planned.

A candidate site for a ramp meter should show flow breakdown on the mainline near the ramp defined by a speed dropping 30 miles per hour (mph) on a regular basis, causing significant delay. The minimum threshold to prompt implementation of ramp metering is 10,000 vehicle hours of annual delay. If data is insufficient to calculate the annual average delay, a measure of the number of annual hours that the freeway speed falls below 30 mph should be used with a minimum threshold of 100 hours.

1.3. Traffic Volumes

The key criteria for ramp metering, in accordance with the FHWA guidance as shown in Figure 1, are that ramp volumes should be ideally between 400 vph and 900 vph per lane, but ramp volumes of 300 to 1,200 vph per lane are acceptable³.

In addition, ramp volumes should ideally be between 10 and 30 percent of downstream mainline freeway traffic flow, although between 5 and 50 percent is acceptable. The ramp flow should be high enough that restricting it has an impact on congestion, but not so high that it cannot be metered without causing congestion on surface streets. This requirement is generally met by any site meeting the ramp volumes requirement above.⁴

Finally, downstream flows should be more than 1,100 vph per lane. Again, this requirement is generally met by any site meeting the requirement for sufficient congestion.

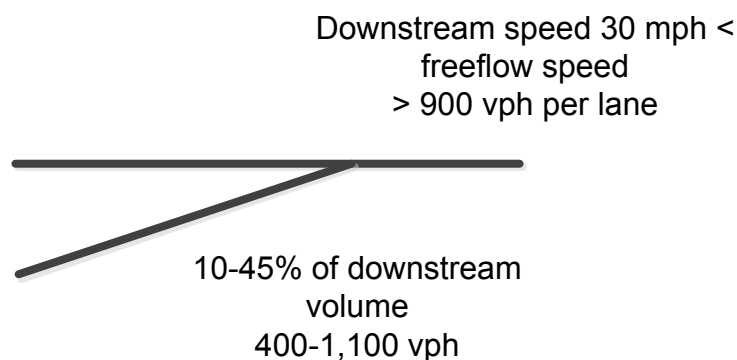

Figure 1: Ideal Criteria for Ramp Metering

³ *Ramp Management and Control Handbook*, Federal Highway Administration, 2006

⁴ *Interim Advice Note 103/08*, UK Highways Agency, 2008

If the maximum entrance ramp volumes per lane exceed those defined above, installation of a standard ramp meter may lead to excessive queuing on the entrance ramp and possibly the intersecting crossroad. In these instances, one of the following should be considered:

- Reconstructing the entrance ramp to increase the number of lanes to improve storage capacity and reduce the entrance ramp volume per lane
- Providing additional control measures such as active traffic management applications

1.4. Crashes

No specific crash rate has been adopted as a standard used to justify the implementation of ramp metering. Crash data to date has not been considered a standard for site selection. However, a reduction in accidents at the merge is often cited as a reason for ramp metering, and evaluation studies have found an average of 14.6 percent to 20 percent reductions in the crash rates for rear end and sideswipe accidents, respectively, in the vicinity of the gore or on the ramp.

2. Design

Ramp meter site design consists of a combination of geometric, signalization, signing, and pavement marking standards. The recommended approach for ramp meter site design is as follows:

1. Determine position of the stop bar.
2. Determine pavement markings and signing
3. Determine position of the traffic signal heads and supports.
4. Determine position of the ramp traffic detectors.
5. Identify mainline freeway traffic detectors upstream and downstream of ramp meter site. Placement is software specific.
6. Determine position of the ramp meter controller, cabinet, and associated infrastructure.

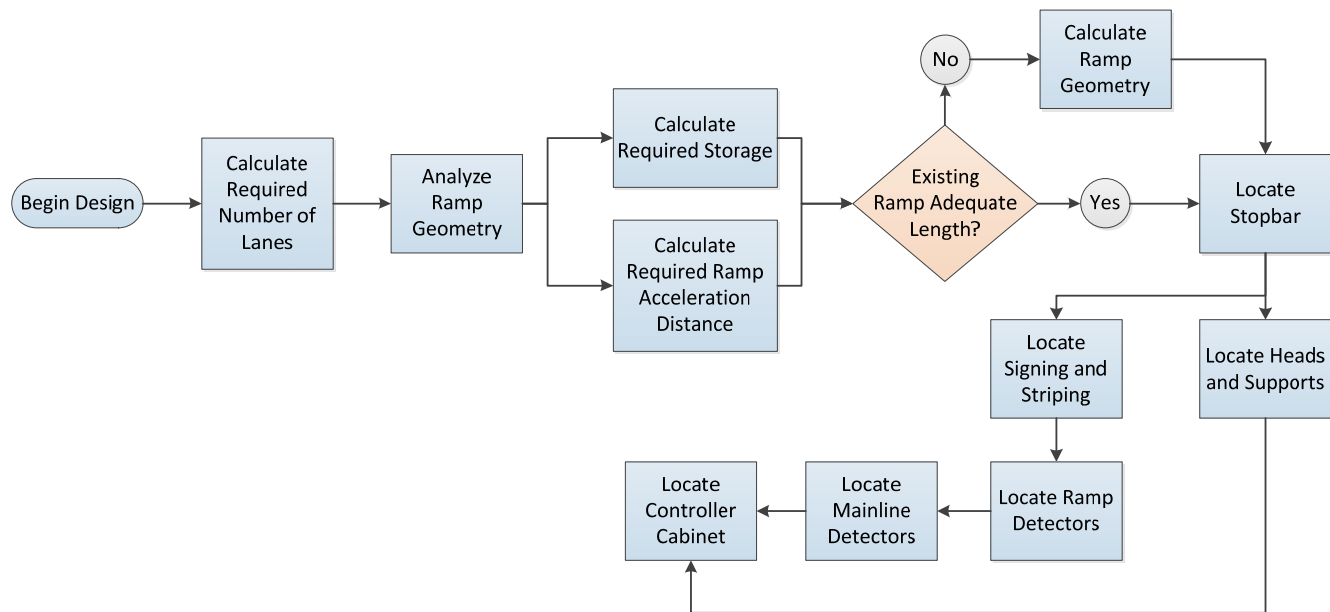

Figure 2: Site Design Process

2.1. Basic Ramp Metering Components

The basic components of a ramp meter site are shown in Figure 3 and include:

- Traffic signal heads and supports
- Ramp meter controller, cabinet, and associated infrastructure
- Mainline freeway traffic detectors upstream of ramp meter site
- Ramp traffic detectors (queue, demand, and passage detectors)
- Pavement markings
- Traffic signing including advance ramp control warning signs
- Optional enforcement features

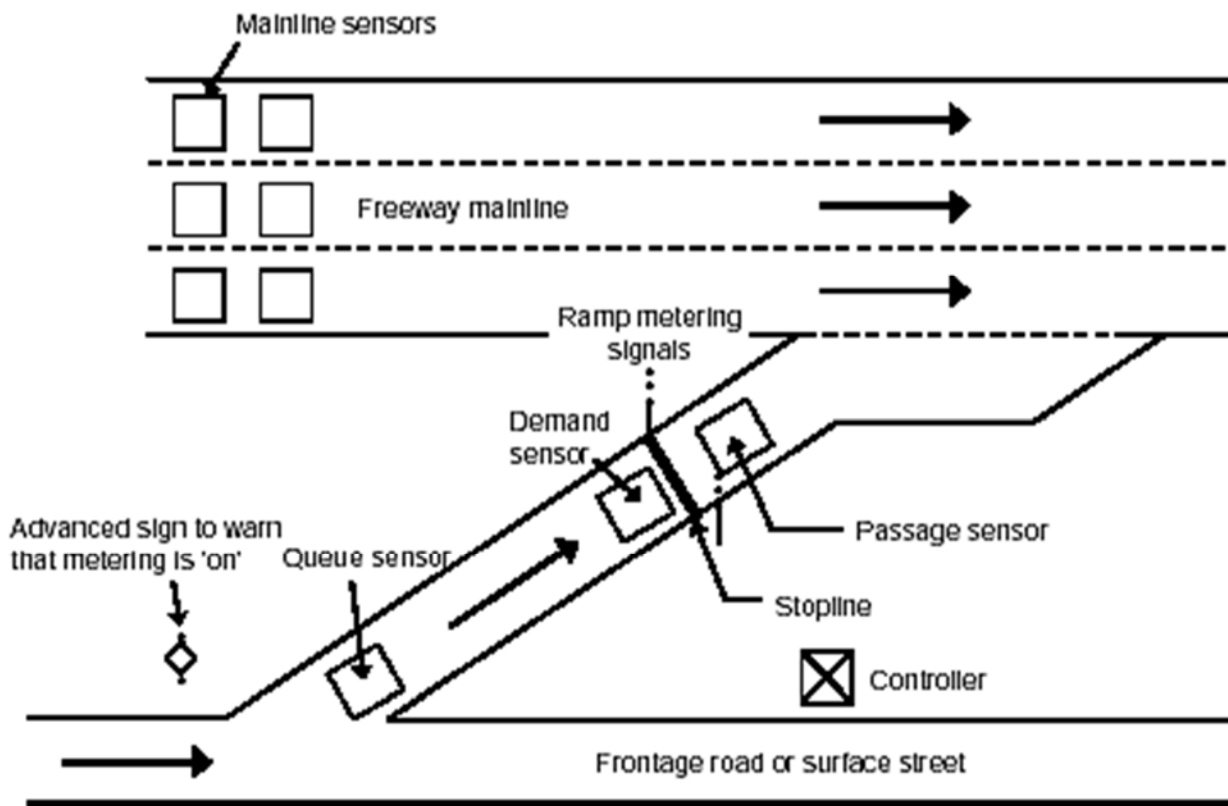

Figure 3: Typical Ramp Meter Site Layout

2.2. Geometric Standards

2.2.1. Stop Bar Placement

As detailed in Section 2.2.8, Queue and Acceleration Distance, the stop bar should be located to provide the calculated storage for queuing vehicles. Determining the optimal position for the stop bar is the most critical decision in the design of a ramp meter site. The location of the stop bar must also provide vehicles with the distance to accelerate to the same speed as, and merge safely with, the mainline freeway traffic at the ramp gore. The location of the stop bar has an impact on safety and governs visibility for the drivers approaching the queue on the entrance ramp. Minimum acceleration lengths for entrance ramps are identified in Exhibit 10-70 of AASHTO's *A Policy on Geometric Design of Highways and Streets*. The stop bar position must meet all of the following conditions:

- A stationary vehicle behind the stop bar can accelerate to reach the same speed as traffic traveling in the outside lane of the freeway during ramp meter operation by the time the vehicle reaches the ramp gore.
- There is a sufficient storage area for queuing vehicles on the entrance ramp. There must be a minimum distance of 250 feet from the stop bar to the queue loops to allow

for the minimum provision of two queue detection loops per lane, as detailed in the figures in the Appendix.

- There is visibility of the signal heads approaching the stop bar.
- Freeway conditions at and immediately upstream of the gore must be visible from any vehicle stopped at the stop bar.

The anticipated ramp metering switch-on speed is the speed anticipated in the outside lane of the freeway during ramp meter operation. The anticipated ramp meter switch-on speed is related to the distance from the point of flow breakdown to the ramp gore. If the point of flow breakdown is more than 1.25 miles from the ramp gore, the anticipated ramp meter switch-on speed will be higher, as the ramp meter system will be operational earlier, in order to prevent congestion from flowing back to the merge area. If the point of flow breakdown is closer to the ramp gore, then the anticipated ramp metering switch-on speed will be lower. The anticipated ramp-metering switch-on speed is typically between 45 mph and 55 mph. An incorrect switch-on speed can result in the following impacts:

- The ramp meter system becomes operational too late, after flow breakdown has already occurred, and does not provide the maximum benefit possible.
- Vehicles are not able to reach the necessary speed to merge safely with the outside lane of the main freeway.

If the distance from the gore to the stop bar is too great, consecutive vehicle platoons may meet prior to merging with the freeway, making merging with the outside lane of the freeway more problematic than if the two smaller platoons remained separated.

2.2.2. Lane Widths

NCDOT has the following roadway design guidelines⁵ for single lane ramp lane widths:

- 14 feet minimum
- 16 feet when traffic or truck percentages are high
- 16 feet for interstate facilities and all with 4-foot paved inside and outside shoulders.

NCDOT has the following roadway design guidelines⁶ for dual lane ramp lane widths:

- 12-foot lanes for all facilities with dual lane ramps with 4-foot paved inside and outside shoulders.

The typical design of other states' ramp meter installations is 12-foot lanes, which:

- Permit standard loop sizes with better sensitivity.
- Reduce the chances that motorcycles will not be detected.
- May slow traffic through the ramp meter area.
- Minimize lane widening in multi-lane installations.

⁵ *Roadway Design Manual*, North Carolina Department of Transportation, 2012

⁶ *Roadway Design Manual*, North Carolina Department of Transportation, 2012

The standard lane width in the vicinity of the ramp meter is 12 feet. If sufficient width is available, additional lanes can be provided on the ramp to increase vehicle storage. Ideally, multi-lane entrance ramps should transition to a single lane width between the stop bar and the ramp gore. The lane drop transition from the multi-lane segment to the single lane segment should occur with a taper rate of at least 50:1. A lesser taper may be acceptable in situations where there are geometric or right-of-way constraints, as long as safety is not compromised.

2.2.3. Shoulder Widths

NCDOT has the following design guidelines⁷ for ramp shoulder widths:

- Inside Shoulder – 14 ft. desirable, 12 ft. minimum (right side of traffic)
- Outside Shoulder – 12 ft. desirable, 10 ft. minimum (left side of traffic)
- When guardrail is warranted, the minimum shoulder width is increased by 3' – 0"
- Paved shoulders are required on both sides.
 - 4' minimum full depth paved shoulder is the standard application.
 - In areas with high truck volumes 12' full depth paved shoulders should be considered.
 - Paving to the face of guardrail may be considered in areas where 12' paved shoulders are utilized.

2.2.4. Pavement Width Transitions

Merge tapers follow the MUTCD formulas based on design speed and amount of lateral shift:

$L = WS$ where L is taper length and S is speed in mph and W is the lateral shift in feet for speeds greater than or equal to 45 mph.

$L = WS^2/60$ where L is taper length and S is speed in mph and W is the lateral shift in feet for speeds less than or equal to 40 mph.

Pavement transitions in the form of shifting tapers follow the MUTCD formulas based on design speed and amount of lateral shift:

$L = WS/2$ where L is taper length and S is speed in mph and W is the lateral shift in feet for speeds greater than 40 mph.

$L = WS^2/120$ where L is taper length and S is speed in mph and W is the lateral shift in feet for speeds greater less than or equal to 40 mph.

2.2.5. Clear Zone Setbacks

The traffic signal assemblies and all associated ramp metering infrastructure will be designed to be located outside of the ramp and mainline freeway clear zone, as required by AASHTO *Roadside Design Guide*⁸ or protected by appropriate protective devices. NCDOT has

⁷ *Roadway Design Manual*, North Carolina Department of Transportation, 2012

⁸ *Roadside Design Guide*, AASHTO, 2011

approved breakaway or frangible pedestal poles suitable for placement in the clear zone. It is preferred the poles and cabinet be placed behind guardrail, if it exists. If the installation of the traffic signal poles or other equipment within the clear zone cannot be avoided, the poles must be installed on breakaway bases or protected by guardrail or barrier wall. The cabinet shall be either protected by guardrail or placed outside the clear zone.

2.2.6. Restricted Use Lanes

Restricted use lanes are lanes dedicated to special vehicle types, vehicle occupancies, or specific operating hours. As an example, NCDOT's "BOSS" (Bus on Shoulders) project operates approved transit buses on shoulders along I-40 in the Research Triangle Park and in the Garner/Clayton areas. From a transit perspective, a restricted use lane at a ramp meter for transit vehicles could be supportive of the BOSS project and any transit initiatives to increase ridership.

Other states have placed restricted transit lanes on both the left and right side of the ramp. In support of the BOSS project in the Research Triangle Park and Garner/Clayton areas, the restricted lane for transit bypass is located on the right for the following reasons:

- 1) Merges to the right are difficult for buses and trucks because of their right-side blind spots, even though they would be expressed through the ramp metering.
- 2) Generally, it is good design to have slower vehicles to the right. Even though the design gives the bus preferential treatment to bypass, a bus still accelerates much slower than a car.
- 3) If the transit bypass lane extends to the ramp gore, there would be a more logical transition to the right shoulder within the BOSS study area, rather than making a weave or lane change maneuver from the left lane to the outside shoulder.

2.2.7. Sight Distance

Adequate sight distance from upstream on the ramp to the ramp meter stop bar and of the queue storage area is a primary geometric consideration when analyzing a site for installation of a ramp metering system. Sight distance should be determined from requirements set forth in Exhibit 3-1 of AASHTO's *A Policy on Geometric Design of Highways and Streets*⁹ (see Table 1 below).

Ramps where minimum stopping distance cannot be achieved are not candidates for ramp meters. Limited sight distance on tightly curved or loop ramps makes it difficult to install a ramp meter and still meet the minimum stopping distance requirements. Additional design measures, as discussed in Section 2.2, should be examined prior to implementing ramp metering systems on such ramps.

⁹ *A Policy on Geometric Design of Highways and Streets*, AASHTO, 2011

Table 1. AASHTO Stopping Sight Distance

Design Speed (mph)	Stopping Sight Distance (ft.)
25	155
30	200
35	250
40	305
45	360
50	425
55	495
60	570
65	645
70	730
75	820

2.2.8. Queue and Acceleration Distance

In addition to sight distance, the availability of queue storage space, adequate acceleration distance, and merge area beyond the meter are also primary considerations for determining if a ramp’s physical characteristics are suitable for ramp metering. Adequate queue storage space is determined based on the ramp’s projected volume; adequate acceleration distance, provided in the following table for acceleration from the stop condition as would be the case when a ramp meter is in operation, is determined from Table 10-3 of AASHTO’s 2011 *A Policy on Geometric Design of Highways and Streets*¹⁰. These distances are shown in Table 2. Balancing queue storage space and acceleration distance to the freeway is critical in the placement of the ramp meter stop bar along the ramp.

When a ramp meter is in operation, the ramp should satisfy the following requirements:

- Provide sufficient distance between the stop bar and the freeway for vehicles to accelerate to the desired operational speed
- Provide sufficient storage upstream of the stop bar for queuing vehicles so that the queue does not back up beyond the ramp entrance

The acceleration distances for ramp meter operation shall be based upon the required acceleration distance from a stopped condition to the operating speed of the freeway when the ramp meter is in operation. That speed is typically around 50 mph. Therefore, the acceleration distance would be 720 feet.

¹⁰ *A Policy on Geometric Design of Highways and Streets*, AASHTO, 2011

Table 2. AASHTO Minimum Acceleration Lengths for Entrance Ramps

Freeway Design Speed (mph)	Acceleration Length from Stop Condition (ft.)
30	180
35	280
40	360
45	560
50	720
55	960
60	1200
65	1410
70	1620
75	1790

The required queue storage is based on the ramp volume, meter release rate, and assumed vehicle length (typically 25 feet). Storage should be provided for 10 percent of the pre-metered peak-hour ramp volume while trying to contain the queue within the available ramp storage. Queues can also be estimated using the following equation for the 95 percentile from Texas Transportation Institute (TTI).

$$L = 3.2808 \times (.250V - .00007422V^2)$$

L = Required storage in ft.
 V = Demand volume in vph

This equation can be summarized in Table 3.

Table 3. Queue Distance

Volume	Storage Length (ft.)	
	One Lane	Two Lane
800	501	251
900	541	271
1000	577	289
1100	608	304
1200	634	317
1300	655	328
1400	672	336
1500	683	342
1600	689	345

If the queues from the ramp meter exceed the available ramp storage, several candidate strategies are available:

- Add an additional lane on the ramp to shorten the required length of the combined queue
- Adjust the metering rate to reduce the queue
- Allow platooning (increasing the release rate beyond one vehicle per green)
- Provide real-time driver information via dynamic message signs (DMS) on the ramp with specific delay information
- Provide additional storage on the adjacent surface streets, although this is undesirable as it creates congestion and degraded levels of service on the surface street

2.2.9. Number of Lanes

Per FHWA's *Ramp Management and Control Handbook*¹¹, "... the number of lanes necessary along a metered freeway ramp shall be based on the ramp volume, calculated queue storage, meter release rate, and available ramp width." For single lane with individual release of vehicles, using a minimum cycle time of 4 seconds (2.5 seconds of red time plus 1.5 seconds of green time), the maximum discharge rate of a single metered lane is 1,000 vph. General guidelines to determine the number of metered lanes and their corresponding release rate-based entrance ramp volumes are shown in the following table.

Table 4. FHWA Ramp Meter Operation Guidance - Number of Lanes and Release Rate

Ramp Volume	Suggested Number of Metered Lanes	With Suggested Release Rate
<1,000 vph	One	One vehicle per green
900–1,200 vph	One	Two vehicles per green
1,200–1,600 vph	Two	One vehicle per green
1,600–1,800 vph	Two	Two vehicles per green

2.2.10. Ramp Merging

NCDOT's design practice on merging of multi-lane ramps stipulates the merge cannot take place through the gore area. The merge of one ramp lane into another ramp lane must occur either upstream of the back of gore or downstream of the tip of gore as shown in Figures 4 and 5.

¹¹ *Ramp Management and Control Handbook, FHWA, 2006*

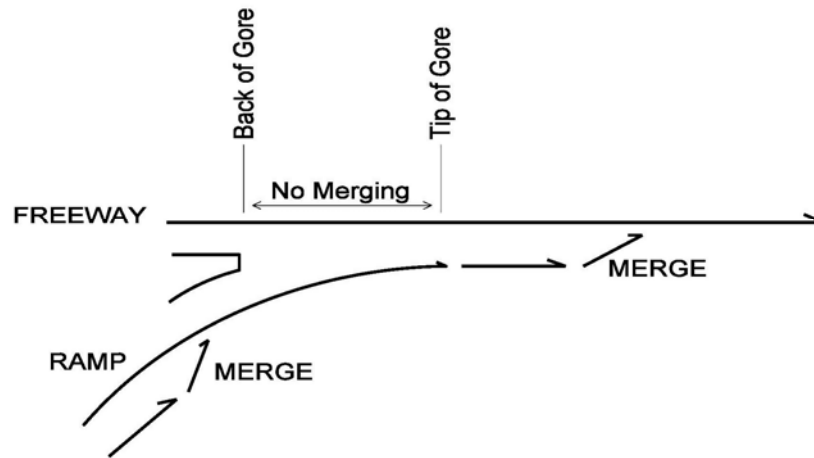

Figure 4: Option 1: Ramp Merge Upstream of Gore

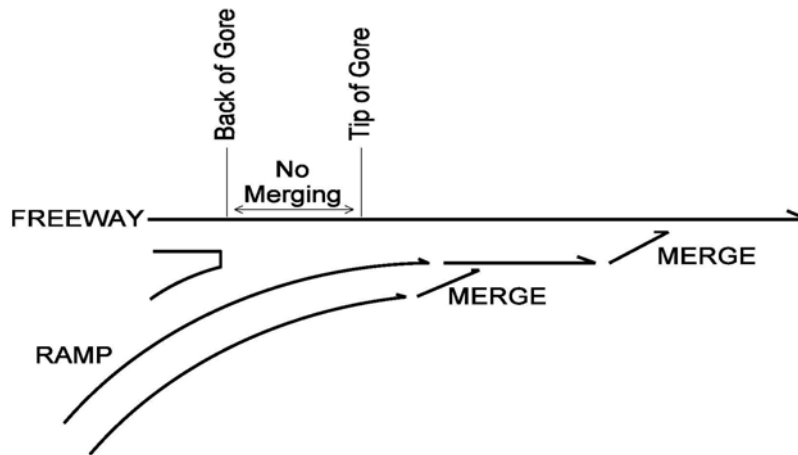

Figure 5: Option 2: Ramp Merge Downstream of Gore

2.2.11. Typical Ramp Meter Layouts

In Appendix B, six typical ramp meter geometric layouts are shown:

1. **Single Lane Ramp Meter Overview (Figure B-1):** The preferred placement of the signal heads is either pedestal pole or mast arm mounted. Mast arm mounting can be used where geometric constraints exist. The basic layout assumes no widening required.
2. **Two Lane Ramp Meter Overview (Figure B-2):** The preferred placement of the signal heads is either pedestal pole or mast arm mounted. Mast arm mounting can be used where geometric constraints exist. This alternative differs from a single-lane ramp meter with additional detection on the ramp, longer mast arm(s) (if used), and

additional pavement markings. The alternative may or may not require widening; the extent and the need for any widening would be a site-specific issue.

3. **Three Lane Ramp Meter Overview (Figure B-3):** The required placement of the signal heads is mast arm mounted due to the MUTCD requirement of one head per lane during independent operation. This alternative differs from a two-lane ramp meter with additional detection on the ramp, required mast arm(s), and additional pavement markings. The alternative may or may not require widening; the extent and the need for any widening would be a site-specific issue.
4. **Single Lane Ramp Meter with Transit Bypass Overview (Figure B-4):** This alternative differs from two-lane ramp meters by having a different detection scheme in the second (bypass) lane. There would be some additional signing for the bypass lane and some changes in the pavement markings. To ensure lane discipline, a traffic separator between the lanes is required, which would likely necessitate some widening; the extent and the need for any widening would be a site-specific issue.
5. **Single Lane Freeway-to-Freeway Ramp Meter Overview (Figure B-5):** This alternative differs from a basic single-lane ramp meter with additional advance warning signing. The clear zone setbacks are greater due to increased speed. Detection may change due to approach speed of the ramp. The basic layout assumes no widening required.
6. **Two Lane Freeway-to-Freeway Ramp Meter Overview (Figure B-6):** This alternative may or may not require widening (site-specific issue). This alternative differs from single-lane freeway-to-freeway ramp meters with additional detection on the ramp and additional pavement markings being needed.

2.3. Signalization Design Standards

Ramp meters must use displays that meet standard design specifications per FHWA's *MUTCD*, Sections 4D and 4I and subsequent clarifications made by FHWA since the last publication of revisions to the *MUTCD*. As written, Section 4I.02 requires that separately controlled, multi-lane ramp meters must have two signal heads per lane and one signal head must be mounted overhead for each lane. However, subsequent to the publishing of the *MUTCD*, FHWA received and responded to two requests for an official interpretation. FHWA ruled in January 2011:

- Each single-lane ramp meter and multi-lane ramp meter with simultaneous green indications must have two signal heads
- Separately controlled multi-lane ramp meters must have two signal heads per lane and they do not have to be overhead mounted. The two signal heads per lane may be overhead, post-mounted, or a combination of both.
- If the ramp meter has three separately controlled lanes, then one signal head shall be mounted over the approximate center of each lane and additional side-mounted signal heads should be considered.

In February 2013, FHWA made a second official interpretation that requires only one signal head per lane for two independently controlled lanes of a ramp meter.

2.3.1. Signal Supports and Signal Head Placement

Signal supports may be either pedestal pole or mast arm signal poles, but must comply with the NCDOT *Traffic Management and Signal Systems Design Manual*¹² to be located downstream of the stop bar, outside of the clear zone, or otherwise protected as mentioned in Section 2.2.5, Clear Zone Setbacks. The height of the signal heads when mounted over the roadway must not exceed 25.6 feet. Ramp meter signal heads must be placed to be visible to vehicles approaching the stop bar, but also designed to minimize their viewing by mainline freeway traffic. The signal head placement shall meet the following criteria:

- Single-lane ramp meters may be pedestal pole-mounted signals at or very near the stop bar.
- Mast arm mounting is optional and site conditions may necessitate mast arm mounted.

The placement of signal heads for multi-lane ramp meters is governed by how the ramp meter operates. A ramp meter can operate with all the lanes having a simultaneous green or the ramp meter can display green for each lane independently so only one lane is green at any one time. FHWA has clarified the National Committee for Uniform Traffic Control Devices (NCUTCD) decisions to require:

- Simultaneous Operation: Two lanes per approach are required and the heads may be post or overhead mounted as conditions dictate.
- Independent Lane Operation:
 - Post mounted with a minimum of two heads per approach.
 - Overhead mounted if there are three or more lanes with one head placed over the center of each lane.

NCDOT requested development of a design to include a one-lane ramp meter with restricted use transit bypass lane to support HOV and transit operations. That design provides the following design options:

- Pedestal pole mounted signals with the right side signal pedestal pole on a 4-foot traffic separator or
- Mast-arm mounted signals over the stopped lane only at or very near the stop bar

Freeway-to-freeway ramp meters pose greater safety risk when stopping higher design speed ramp traffic. Therefore, it is recommended beyond the MUTCD requirements to mount freeway-to-freeway ramp meter signal heads overhead for maximum viewing.

¹² *Traffic Management and Signal Systems Design Manual*, North Carolina Department of Transportation, 2012

If the signal heads are mast arm mounted, one signal head is located above the center of each metered lane.

If the signal heads are pedestal pole-mounted, then two signal heads are provided for each lane for independent operation and are located on each side of the lane(s) with visibility from the mainline of the freeway restricted. Regardless of the number of approach lanes on a ramp, the *MUTCD* requires a minimum of two signal heads to be installed per ramp.

These requirements are summarized in Table 5 as they apply to NCDOT's decisions on ramp meter operations where multi-lane ramp meters will operate with independent operation as described above:

Table 5. Signal Head Placement Requirements

Lane Configuration	No. of Lanes	Head Placement	No. of Heads/ Approach
Local Street to Freeway, no Transit Bypass	1	Pedestal Pole or Overhead	2
Local Street to Freeway, no Transit Bypass	2	Pedestal Pole or Overhead	2
Local Street to Freeway, with Transit Bypass	2	Pedestal Pole or Overhead	2
Freeway-to-Freeway	1	Overhead	2
Freeway-to-Freeway	2	Overhead	2
Freeway-to-Freeway	2+	Overhead	2+

If a pedestal pole is used, then two signal heads must be mounted on the pedestal pole. One signal head is aligned with approaching traffic further upstream, and the second signal head faces traffic at the stop bar.

The preferred location of the ramp meter pedestal pole is the left side of the ramp. In this location, the signals can be oriented so mainline traffic cannot see and potentially be confused by the displays.

Signal heads are not necessary for unmetered lanes, and ramp meter signals may be put in dark mode (no indications displayed) when not in use. An additional status indicator light may be installed on the backside of the signal for enforcement. This indication would be lit only when the ramp meter signal is red to assist the monitoring officer in knowing when a driver ran the light.

2.3.2. Signal Head Displays and Phasing

The *MUTCD* provides the latitude to use either two- or three-section signal heads. The number of sections depends on how the ramp meter will operate. The single lane per green operation provides the highest capacity due to the absence of clearance intervals. On July 2,

2014, the NC General Assembly enacted legislation to require two-section ramp meter signal heads.

The MUTCD also permits the ramp meter signal heads to display an indication or to be dark when not in operation. Most states leave ramp meters dark when not in operation. Some states use advance warning signs with flashers that are activated when the ramp meter is in operation.

The ramp meter signals will be dark when not in operation, and pedestal pole-mounted warning signs with flashers (as described in Section 2.4) will be used to indicate when the ramp meter is in operation.

2.3.3. Controllers and Cabinets

Ramp meters are controlled by traffic signal controllers, which use specialized software embedded in the controller (firmware) that differs from traffic intersection control firmware. This firmware operates the ramp metering strategies employed. The firmware can operate on NEMA, ATC or Caltrans model controllers (170, 179, and 2070). NCDOT has determined for its first deployment the selection of the software will determine the controller/cabinet type.

Just as each traffic signal-controlled intersection requires a controller cabinet assembly, each ramp meter location also requires a controller cabinet. Equipment required for a ramp meter cabinet is similar to a controller cabinet at a traffic intersection. Cabinet location requirements, such as clear zone, maintenance pad, and safety requirements, are typically the same for ramp meter cabinets and traffic signal cabinets. Ramp meter cabinets should be located upstream of the stop bar in a location so that the ramp signal heads are visible from the front door of the cabinet for troubleshooting purposes. The cabinet location should also comply with distance requirements for any inductive loop detectors being used. In general, the preferred location is on the outside of the ramp to minimize conduit length and the number of directional drilled conduits under the ramp.

Ramp meter controller cabinets will need communications equipment, such as a fiber-optic patch panel and appropriate communications hardware to the regional transportation management center (TMC). Another option is to use cellular modem communications to reduce costs of the communications network. This will allow TMC operators to remotely control ramp meter functions, monitor equipment status, and, if necessary, override the local operation.

2.3.4. Typical Ramp Metering Signal and Equipment Layouts

In Appendix C, four recommended typical ramp meter layouts are shown. Each layout includes the standards for the required, recommended, and optional equipment and layout with installation notes:

1. Single Lane Ramp Meter Signalization and Equipment Layout (Figure C-1)
2. Single Lane Ramp Meter with Transit Bypass Signalization and Equipment Layout (Figure C-2)

3. Two Lane Non-Freeway-to-Freeway Ramp Meter Signalization and Equipment Layout (Figure C-3)
4. Freeway-to-Freeway Ramp Meter Signalization and Equipment Layout (Figure C-4)

2.3.5. Vehicle Detection

As noted in Section 2.1, Basic Ramp Metering Components, several types of detectors are required in the operation of ramp meter signals:

- Freeway or mainline
- Demand
- Passage
- Transit interrupt
- Queue

The freeway or mainline detectors are located upstream of the ramp merger and collect speed and volume in each lane. Each lane has a pair of detectors to measure speed.

The demand detectors are located on the ramp upstream of the stop bar to place a call in the ramp meter controller for a vehicle waiting for a green indication. The detectors are located in a series to create a 30' detection zone.

The passage detector located downstream of the stop bar extends the green call before the indication turns red.

The transit interrupt detector is located in the transit bypass lane to preempt the ramp meter to stop the vehicles in the general purpose lane so the transit vehicle can proceed.

The queue detectors are located on the ramp in each lane several hundred feet upstream of the stop bar at the ramp meter. They sense the presence of an undesirable stationary queue and place a call into the ramp meter controller to change the metering rate to dissipate the queue.

2.3.5.1. Detection Technology

Inductive loops are better than any other technologies in their ability to collect queue and presence data. Inductive loops will be used on the ramps for demand, passage, and queue detection as described below.

On the mainline of the freeway, only volume and speed—not presence and queuing—are collected. In this application, microwave detection would normally be preferred because of the life cycle costs, including traffic control costs, to install and maintain is less than that of inductive loops. However, NCDOT has had concerns about the reliability of microwave detectors and the cost to keep them calibrated. Inductive loop detection technology will be used on the freeways as these detectors are less prone to lighting conditions and visibility issues.

2.3.5.2. Demand Detectors

Demand or presence detectors are used to detect the presence of a vehicle at the ramp meter stop bar and initiate the ramp metering cycle. They should include a series of three 6-foot by 6-foot induction loops centered in each lane, with the first being 3 feet upstream from the stop bar. The remaining two loops should be spaced at 5-foot intervals upstream of the first loop.

2.3.5.3. Passage Detectors

Passage detectors are used to detect and count the number of vehicles that enter the freeway, which can be used to determine the duration of the green signal display. They should include one 6-foot by 6-foot induction loop centered in each lane, located 3 feet downstream from the stop bar.

2.3.5.4. Queue Detectors

Advance queue detectors¹³ monitor excessive queues on the entrance ramps to determine if the queue exceeds the ramp storage capacity. If the ramp queue vehicle detectors identify that ramp queues are about to back up onto surface streets, the ramp meter controller and software will utilize its queue management algorithms to alter the cycle lengths and release rates to prevent the queue from spilling back onto the cross street. It is recommended that one 6-foot by 6-foot induction loop be centered in each lane, located 115 to 330 feet downstream of the cross street. Additional intermediate queue detectors may be located along the ramp to monitor ramp queues and attempt to dissipate them before they back up to the surface street. The advance queue detector is used to accelerate the discharge rate when the queue is close to spilling back upstream onto the surface street.

Table 6 illustrates the formula to locate the advance queue detector. X is the distance between the surface street and the ramp meter stop bar. The maximum AQD distance is 300 feet from the surface street to the downstream edge of the detector for ramps less than 1,200 feet. For ramp lengths greater than 1,200 feet, AQD = 300 feet.

¹³ *Ramp Meter Design, Operations, and Maintenance Guidelines*, Arizona Department of Transportation, 2003

Table 6. Calculation of Advance Queue Detector Location

Design Hour Volume (VPH)	AQD Formula
DHV > 1,080	AQD = 0.39X
1,080 > DHV > 900	AQD = 0.34X
900 > DHV > 720	AQD = 0.28X
DHV ≤ 720	AQD = 0.25X

2.3.5.5. Considerations for Specific Interchanges

Certain interchange configurations require special treatment. These interchange types include Single Point Urban interchanges (SPUI) and Diverging Diamond interchanges (DDI).

SPUI’s, as shown in Figure 6, feature a single intersection for all the movements to and from the freeway. Typically, this single intersection, which combines the movements of two smaller intersections found in diamond interchanges, have longer cycle lengths.

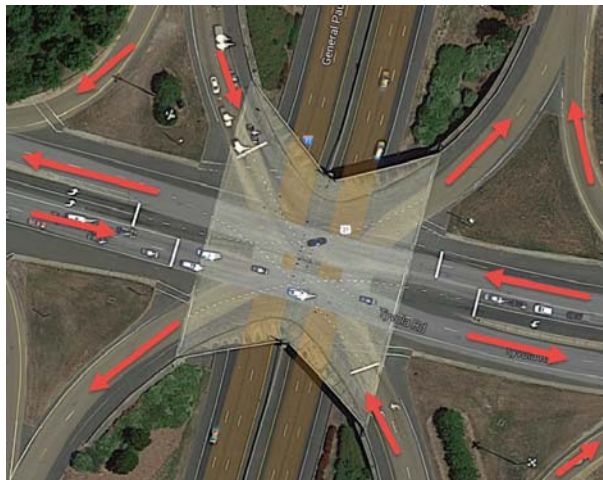

Figure 6: Single Point Urban Interchange

Long travel times across the larger SPUI also contribute to longer cycle lengths. The longer cycle lengths increase the size of the platoon releasing onto the entrance ramp of the freeway and greatly increase the queue at a ramp meter.

For SPUI interchanges, ramp meter design needs to consider and address the following issues:

- 1) Queueing will likely be higher due to the longer traffic signal cycle length. The queuing should be estimated using the methods described in this report to ensure the design will not create excessive queues.
- 2) The addition of intermediate queue detectors between the ramp meter stop bar and the normal queue detector can help to mitigate an over-queue situation by triggering an intermediate metering rate. The typical queue detector location further upstream could

then implement a higher metering rate that could further reduce the queue or even shut off the ramp meter.

- 3) The right and left movements onto an entrance ramp merge further down the ramp than a conventional diamond interchange. Depending on how far down the ramp this merge occurs, it may be necessary to place the queue detectors upstream of the merge of the right and left turn movements as shown in Figure 7.

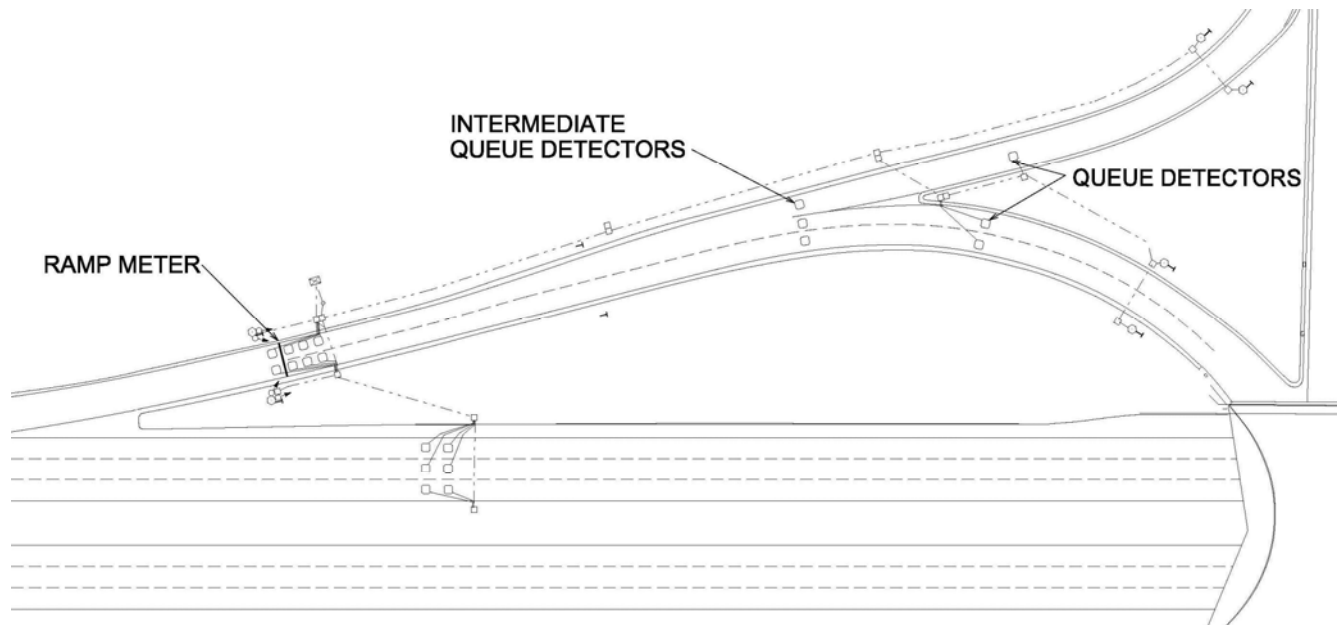

Figure 7: Queue Detection for Single Point Urban Interchange

DDI's, as shown in Figure 8, consist of two two-phase traffic signals and all left and right turns are free flow. There is a triangular island at the beginning of the ramp where the right and left turn movements converge. The cycle lengths tend to be shorter due to the tight design of the intersections and the small number of phases. These conditions tend to reduce the platoon effect, which helps ramp metering. Generally, DDI's do not require special treatment for ramp meter design unless the ramps are short. If they are short, then a treatment can be applied similar to a SPUI.



Figure 8: Diverging Diamond Interchange

2.3.5.6. Transit Interrupt Detector

The transit interrupt detector¹⁴ is used to create a gap in the metered traffic on the ramp for the transit vehicle to enter the freeway. The transit interrupt detector is placed 350 feet upstream of the ramp meter stop bar.

2.3.5.7. Freeway Mainline Detectors

Freeway detectors monitor the freeway flow rate and speed, which are used to provide data to determine the traffic-responsive metering rate. They will be installed 400 feet upstream of the entrance ramp gore point. Mainline freeway detection of volumes and speeds use microwave detection. This technology is not employed for ramp presence detection, as it would require the costly installation of many units.

2.3.6. Typical Ramp Detection Layouts

In Appendix D, three typical ramp detection layouts are shown. Each layout shows the standards for the required detection equipment and their layout with installation notes:

1. Single Lane Ramp Meter Detection (Figure D-1)
2. Single Lane Ramp Meter Detection with Transit Bypass Detection (Figure D-2)
3. Mainline Detection (Figure D-3)

2.4. Signing and Pavement Marking Standards

The presence of ramp meters can catch approaching drivers off-guard. Advance warning signs and markings can help inform drivers that they are approaching a ramp meter, and prepare the driver to come to a stop before entering the freeway. Signs and pavement

¹⁴ *Ramp Meter Design, Operations, and Maintenance Guidelines*, Arizona Department of Transportation, 2003

markings at the ramp meter indicate where to stop and how to proceed. The following section details standard signing and pavement markings for ramp metering design.

2.4.1. Typical Ramp Metering Signing and Pavement Marking Layouts

In Appendix E, three recommended typical ramp meter layouts are shown. Each layout shows the standards for the required, recommended, and optional signing and pavement markings and includes layouts with installation notes:

1. Non-Freeway-To-Freeway Ramp Meter Signing and Pavement Markings (Figure E-1).
2. Single Lane Loop Ramp Meter Signing And Pavement Markings (Figure E-2). From a signing and pavement marking perspective, a single-lane ramp meter on a loop ramp is a variation of the basic single-lane ramp meter. The ramp meter on a loop ramp varies from the above alternative in the layout of advance signing and marking due to the lower design speed and possible restricted sight distance.
3. Freeway-To-Freeway Ramp Meter Signing and Pavement Markings (Figure E-3)

2.4.2. Signing

Signing installed for the purpose of ramp metering must conform to *MUTCD* guidelines described in Chapter 2, Signs, and must consist of warning and regulatory signs.

The typical U.S. practice is to leave the ramp meter dark when not in operation. NCGS 20-158¹⁵ is subject to interpretation as to what a driver should do when the ramp meter signal is dark, since it is a traffic control device not located at an intersection. In the Conclusions and Recommendations section of the Metrolina Ramp Metering Feasibility Study *Legal and Regulatory Review Report*, several alternatives were presented to address a potential concern for enforcement when the ramp meters are not in operation. One alternative involved revising a general statute and the other alternatives included signing solutions. If the general statute cannot be revised to avoid any misinterpretations, the RAMP METERED WHEN FLASHING (W3-8) sign and flashers must be installed in advance of the ramp meter signal near the entrance ramp, or on the arterial on approach to the ramp. This sign and flasher arrangement will clarify that a driver is not to treat the ramp meter as a four-way stop when it is dark and not operating. The sign and flasher will also alert road users of the presence and operation of ramp meters.

For freeway-to-freeway ramps, a second set of RAMP METERED WHEN FLASHING (W3-8) signs and flashers will be installed in advance of the ramp meter signal near the entrance ramp to emphasize the presence of an operating ramp meter.

Once a ramp metering control operation has been chosen (i.e., number of cars permitted per green indication), regulatory signs outlined in the *MUTCD*, Section 2B.56, can be selected for installation adjacent to the ramp control signal faces.

¹⁵*Statutes of the General Assembly*, North Carolina General Assembly 2012.

In addition to the recommended warning and regulatory signs, ramp meter signals may be accompanied by VMS (variable message signs), which allow the agency greater flexibility in controlling the ramp meter's operation.

Table 7, taken from the *MUTCD*, provides recommendations for applicable ramp metering warning signs. Table 8, also taken from the *MUTCD*, provides recommendations for applicable ramp metering regulatory signs.

Table 7. Ramp Meter Warning Signs







Sign	Application	Location
 <p>W3-8</p>	<p>This warning sign is used to inform road users that a freeway entrance ramp is metered and when it is in operation. The sign may be supplemented with a flashing beacon (see discussion below for further information).</p>	<p>Sign shall be installed on the upstream end of the ramp and visible from the cross street.</p>
 <p>W3-7</p>	<p>This warning sign is used to inform the motorists that a stopped condition may be present if the ramp meter is turned on.</p>	<p>Sign shall be installed 400 to 600 feet downstream of <i>RAMP METERED WHEN FLASHING</i> sign (W3-8).</p>
 <p>W4-2</p>	<p>This warning sign is used to inform the motorists of the need to merge with another lane prior to entering the mainline freeway if a Two-Lane ramp merges to single lane</p>	<p>Sign shall be installed 100 feet downstream of the stop bar on the right side of the ramp.</p>

Table 8. Regulatory Ramp Meter Signs

Sign	Application	Location
 <p>R10-28</p>  <p>R10-29</p>	<p>These signs are used to indicate the number of cars permitted per cycle</p>	<p>Located at stop bar, post mounted or mounted on the signal supports.</p>
 <p>R10-6</p>	<p>This regulatory sign is used to identify the stop bar location and to align drivers over the demand detectors upstream of the stop bar.</p>	<p>Sign shall be installed at the stop bar on both sides of the entrance ramp.</p>
 <p>R3-11b</p>	<p>These signs are used to delineate HOV lanes and specific vehicle restrictions.</p>	<p>Install sign at beginning of HOV lane and then halfway down ramp, but not less than 300 feet apart.</p>

2.4.3. Pavement Markings

Pavement markings and raised pavement markers installed for the purpose of ramp metering must conform to *MUTCD* guidelines described in Chapter 3B, Pavement and Curb Markings. If there is more than one metered lane, solid lane lines will be used to separate them. Stop bars installed for ramp metering must extend the entire width of all **metered** lanes and must not be staggered.

2.4.4. Optional Enforcement Area

Enforcement areas are paved pullouts placed immediately downstream of the ramp meter, but before the ramp gore. In Appendix F, the layout of a paved pullout for enforcement is shown. Pullouts provide a safe location for a law enforcement officer to park to observe the ramp meter operation for enforcement. They provide the additional benefit of a staging area for motorist assistance or Incident Management Assistance Patrol (IMAP) vehicles. Paved pullouts should be considered optional features.

3. Operations

3.1. Ramp Metering Operations

There are three types of ramp metering operations commonly used:

1. Time of day
2. Local traffic responsive
3. System-wide traffic responsive

Ramp meters can operate by time-of-day scheduling or traffic-responsive operation based upon traffic sensors or detectors. The following section briefly discusses each type of operation and the algorithms used, and provides recommendations based on the findings of our research.

Ramp meter algorithms are used to determine the metering rate in traffic-responsive systems. The ramp metering operation type determines the type of algorithm needed for the ramp meter to function to its full potential. Accurate data from vehicle detectors are the key input used by ramp meter algorithms.

3.1.1. Time of Day

Time-of-day ramp metering is the most basic type of ramp metering, operating only at pre-set times of day with fixed metering rates based on historical traffic data. Fixed-time ramp meters do not consider real-time conditions other than what was predicted in establishing the operating hours. The time-of-day ramp meters cannot operate at other periods of the days if conditions change due to weather, special events, or unforecasted traffic congestion.

The effectiveness and responsiveness of time-of-day operation are limited. Operation is based upon a predefined set of historical conditions and cannot respond to changes from those conditions. If weather, accidents, or special events occur that significantly alter typical or historical conditions, the ramp meters will be ineffective or possibly not operate.

Since time-of-day operation does not provide the flexibility to adjust to traffic fluctuations, special events, and unanticipated major congestion such as accidents or weather events, it will not be used.

3.1.2. Traffic-Responsive Operation

Traffic-responsive operation includes the ability of the ramp meter to detect when the predefined conditions exist for effective ramp meter operation. The ramp meter equipment includes freeway and ramp detectors to measure volume and speed in order to turn on/off the ramp meter as well as to manage its cycle time. Traffic-responsive operation can be one of two modes—local or system-wide operation.

3.1.2.1. Local Traffic Responsive

Ramp metering using local traffic-responsive operations employs vehicle detection located on the entrance ramp and on the freeway mainline upstream of the ramp. Algorithms are used for determining the metering rate for responsive local ramp meter control based on the real-time traffic conditions on the freeway mainline adjacent to the ramp. The basic concept of this algorithm is that if the freeway volume falls below a predetermined value, then the ramp meter increases the metering rate, permitting more ramp traffic to enter the freeway. If the freeway volume increases above the predetermined value, then the ramp meter decreases the metering rate, slowing the rate at which ramp traffic can enter the freeway. The ability of local traffic-responsive meters to turn on and off throughout the day as conditions dictate is a feature to address congestion not forecasted.

Although local traffic-responsive systems do not consider freeway conditions for the entire freeway network, local traffic-responsive operation will be the minimum standard for NCDOT. It responds to real-time traffic conditions in the vicinity of the ramp while not requiring communications to the central TMC. Local traffic-responsive operation is preferred in areas where the ramp meters are isolated, and there would be no benefit from system-wide traffic-responsive operations, as discussed below.

3.1.2.2. System-Wide Traffic-Responsive Operation

The system-wide ramp metering method builds on the local traffic-responsive operation by adapting to conditions along the entire section of the freeway, not just adjacent to the ramp. System-wide algorithms are complex and must coordinate a group of ramp meters to operate as an integrated system to balance queue delay and to better manage bottlenecks and congestion. These algorithms require communicating the real-time traffic data to a central traffic management system to determine the optimum metering rate for each ramp in the system. System-wide traffic-responsive operation requires communications infrastructure that can connect to a centralized computer-controlled system. This type of operation also helps mitigate possible diversions by drivers who attempt to avoid perceived delays by a ramp meter that is in operation.

A minor disadvantage of this operation is that it requires communications to the traffic management system at the TMC in order to operate. If the communications or central computer fails, the ramp meters will be configured and programmed for a standby plan and revert to local traffic-responsive operation.

However, system-wide operations with real-time communications offer far more advantages. Operators can monitor system performance, equipment operation/status, and make some timing adjustments from the TMC.

If a group of ramp meters will be operated under system-wide traffic-responsive operation, engineering analysis will have to be conducted to determine the exact limits of the system-wide control.

3.1.2.3. Summary

Traffic-responsive operation will be used at all ramp meter locations. If the ramp meter is isolated from other ramp meter locations and there is no likelihood diversions could occur due to its operation, then local traffic-responsive operation should be sufficient. If the ramp meter site is part of a group and, in particular, on the same corridor, or if there are potential diversions due to ramp meter operation, then system-wide traffic-responsive operation is preferred.

It is highly desirable to have real-time communications with the regional TMC for monitoring and operations and should be included wherever possible, even for local traffic-responsive sites, to monitor system performance and equipment operation/status.

3.1.3. Queue Management

Queue management algorithms are used in almost all ramp metering systems. The algorithms mitigate excessive queuing on the ramp in order to prevent the queue from backing up to the cross road and causing a safety hazard. It also prevents drivers from experiencing excessive queue delay that may cause frustration. As the queue builds to an unacceptable length, the algorithm increases the metering rate to reduce the queue. If the queue reaches a critical predetermined level, the ramp meter shuts off to reduce the queue even though it may have negative effects on the freeway operation. Queue management also improves the fairness of ramp metering by giving priorities to vehicles in a long queue.

Local traffic-responsive operation has the capability to manage demand rates when incidents occur on the freeway, decreasing the metering rate at ramps upstream of incidents and increasing the rate at ramps downstream.

Queue management algorithms will be included in the ramp meter installation to manage queues and to prevent additional congestion and safety issues on the cross streets.

Bibliography

AASHTO, *A Policy on Geometric Design of Highways and Streets*, 2011

AASHTO, *Roadside Design Guide*, 2011

Arizona Department of Transportation. (2003). *Ramp Meter Design, Operations, and Maintenance Guidelines*.

California Department of Transportation. (2000). *Ramp Meter Design Manual*.

Cambridge Systematics, Inc. (2002). *Mn/DOT Ramp Meter Evaluation*.

Federal Highway Administration, U.S. Department of Transportation. (2012). *Manual of Uniform Traffic Control Devices*.

Federal Highway Administration, U.S. Department of Transportation. (2006). *Ramp Management and Control Handbook*.

Georgia Department of Transportation. (n.d.). *Ramp Meters*. Retrieved 2012 February from Georgia Department of Transportation:
<http://www.dot.ga.gov/travelingingeorgia/rampmeters/Pages/default.aspx>

Highways Agency (United Kingdom). (2008). *Ramp Metering Technical Design Guidelines*.

Highways Agency (United Kingdom). (2008). *Interim Advice Note 103/08 Advice Regarding the Assessment of Sites for Ramp Metering*.

Levinson, L.Z. (2005). *Balancing Efficiency and Equity of Ramp Meters*. ASCE Journal of Transportation Engineering.

Minnesota Department of Transportation. (2007). *Traffic Engineering Manual*.

Nevada Department of Transportation. (2006) *HOV/Managed Lanes and Ramp Metering Design Manual*

North Carolina Department of Transportation, *Roadway Standard Drawings*, 2012

North Carolina Department of Transportation, *Traffic Management and Signal Systems Design Manual*, 2012

North Carolina General Assembly, *Statutes of the General Assembly*, 2012.

Wisconsin Department of Transportation. (2007). *WisDOT Ramp Metering and Control Plan*.

Appendices

Appendix A. Site Requirements



NCDOT Ramp Metering Feasibility Study Site and System Requirements (Part 1)

Design Issue: Tightly curved ramps, will ramp meters be considered on loop ramps?

Discussion: Concerns were raised about sight distance, acceleration distance and safety of doing so. Atkins commented we would not compromise safety and we would not recommend implementation on a tight ramp unless we were sure sight distance and needed acceleration distance would not be compromised.

Recommendation: Atkins recommended that tight loop ramps not be eliminated from consideration as a solution.

Decision: Steering Committee agreed with recommendation.

Design Issue: Short entrance ramps, will ramp meters be considered on short entrance ramps?

Discussion: Short entrance ramps provide less storage and acceleration distance. There are currently five locations with short ramps, ranging from 325-570 feet. Atkins commented it is likely some will drop out due to low volumes.

Recommendation: Atkins recommended that short ramps be considered provided ramp volumes can be manageable.

Decision: Steering Committee agreed with recommendation.

Design Issue: Number of entrance ramp lanes, can ramps be modified to provide two lanes to accommodate ramp metering?

Discussion: Currently all sites still being studied are single lane ramps. Dual lane ramps can provide more distance for either queuing or acceleration. FHWA expressed concern about expanding to three lanes.

Recommendation: Atkins recommended that two-lane ramp meters be considered at this stage.

Decision: Steering Committee agreed with recommendation.

Design Issue: Entrance ramp drop lane, can the lane drops be revised if required?

Discussion: Lane drops could present challenges if too close to the optimum stop bar location. They could be revised by revising the longitudinal lines to shift the location of the lane drop either upstream or downstream, to resolve these issues at relatively low cost.

Recommendation: Atkins recommended that reconfiguring lane drops be considered at this stage.

Decision: Steering Committee agreed with recommendation.

Design Issue: Operational control method of ramp meter operation

Discussion: Most, either in person or through written comments, felt traffic responsive is the preferred way to go. There was some discussion that traffic responsive would also enable operation when historical patterns did not indicate their need or there were some unforeseen conditions such as special events or accidents. It was noted only traffic responsive control should be used to protect the surface streets.

Recommendation: Atkins recommended that the ramp meters operate in a traffic responsive mode whereby traffic conditions, not historical time of day patterns, dictate when the ramp meters operate.

Decision: Steering Committee agreed with recommendation.

Design Issue: Queue management, should it be included

Discussion: One reviewer noted the ramp meter should have a good public perception and queue management should be included. Another reviewer commented could it be added only where there is an expectation of queuing and could it be added later. It can be added later but there would be added construction, software, calibration, and integration costs to modify the original installation. It was noted queue management should be used to protect the surface streets. Another reviewer commented then inclusion of queue management may make the difference of getting MPO and local jurisdiction support.

Recommendation: Atkins recommended that queue management be included at each ramp meter site.

Decision: Steering Committee agreed with recommendation.



NCDOT Ramp Metering Feasibility Study Site and System Requirements (Part 2)

GEOMETRIC STANDARDS

Design Issue: Ramp meter lane width

Discussion: NCDOT roadway design standards call for typical Interstate ramp lane width of 16'. The typical design of other states' ramp meter installations is to use 12' lanes. 12' lanes will:

- Permit standard loop sizes.
- The narrower lanes will reduce the chances motorcycles will not be detected.
- Reduced lane width may have an effect to slow traffic through the ramp meter area.
- Minimize lane widening in multi-lane installations.

Recommendation: Atkins recommends the lane width at the ramp meter be striped to 12'

Decision: Steering Committee agreed with recommendation.

Design Issue: Location of restricted lane for transit vehicle bypass.

Discussion: Reasons for placing the restricted use lane for transit bypass on the right:

- 4) Merges to the right are difficult for buses and trucks because of their blind spots even though they were "expressed" through the ramp meter.
- 5) Generally, it is good design to have the slower vehicles to the right. While buses are being provided preferential treatment, they accelerate much slower than cars.
- 6) If the HOV lane extends to the ramp gore, there would be a more logical transition to the right shoulder for the BOSS study area rather than making a weave or lane change maneuver from the left lane to the outside shoulder.

Recommendation: Atkins recommends a restricted use lane for transit vehicle to be placed on the right side of the ramp to provide smooth flow for the BOSS project.

Decision: Steering Committee agreed with recommendation.

Design Issue: The use of enforcement areas and "tattle-tale lights"

Discussion: Many states, most notably Arizona and California include in their designs two features to enhance enforcement. One is a paved pullout just past the ramp meter and before the gore to allow law enforcement vehicles to pull over to monitor the ramp meter when in operation. In addition, they have a "tattle-tale" light on the backside of the ramp meter

facing the enforcement area so an officer can see the red indication and know when someone ran the light.

Recommendation: Atkins recommends these if the committee feels they would actually be used by law enforcement.

Decision: Steering Committee agreed with recommendation.

Signalization Design Standards

Design Issue: Signal supports and head placements

Discussion: Recommendations for signal head placement and their supports is linked to the type of ramp meter as follows:

- 1) Single-lane ramp meter: post mounted signals at or very near the stop bar or mast-arm mounted signals.
- 2) Two-lane ramp meter without any restricted use lanes: post mounted signals at or very near the stop bar or mast-arm mounted signals.
- 3) One lane ramp meter with restricted use transit bypass lane: pedestal mounted signals with the right side signal pedestal on a 4' traffic separator or mast-arm mounted signals over the stopped lane at or very near the stop bar.
- 4) Freeway to freeway ramp meter (single or dual lane): signal heads overhead mast arm mounted for maximum viewing.

Recommendation: Atkins recommends the placement as described above.

Decision: Steering Committee agreed with recommendation.

Signing Design Standards

Design Issue: freeway-to-freeway advance warning

Discussion: Recommendations for freeway-to-freeway advance warning signs are as follows:

- 1) Two two-line variable message signs with flashers that say: "Ramp Meter On" followed by "Prepare to Stop".
- 2) W3-8, metered when flashing signs with flashers downstream of variable message signs above.

Recommendation: Atkins recommends the placement as described above.

Decision: Steering Committee decided to replace the variable message signs with static signs and flashers.

Appendix B. Typical Ramp Meter Layouts

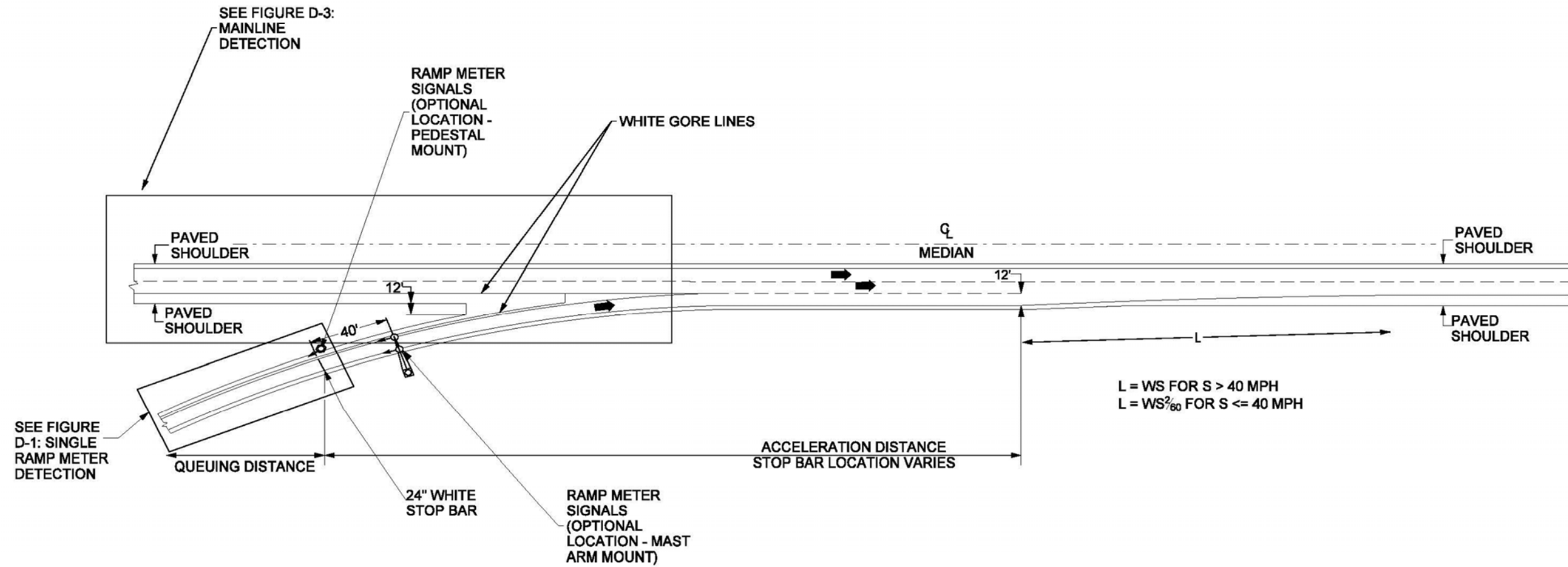

Notes

1. When truck volumes exceed 5% on 3% or greater ascending grades, provide 500' of auxiliary lane between the ramp meter stop bar and point where the ramp and mainline edges of pavement are 10' apart.
2. See AASHTO Exhibit 3-1 for acceleration distances.
3. Signal heads may be pedestal mounted or mast arm mounted as site conditions dictate for single lane applications.
4. See Figure C-1 for signalization and equipment.
5. See Figure D-1 for ramp meter detection.
6. See Figure D-3 for mainline detection.
7. See Figure E-1 for ramp meter signing and pavement markings.
8. See Figure E-2 for loop ramp signing and pavement markings.

Figure B-1: Single Lane Ramp Meter Overview

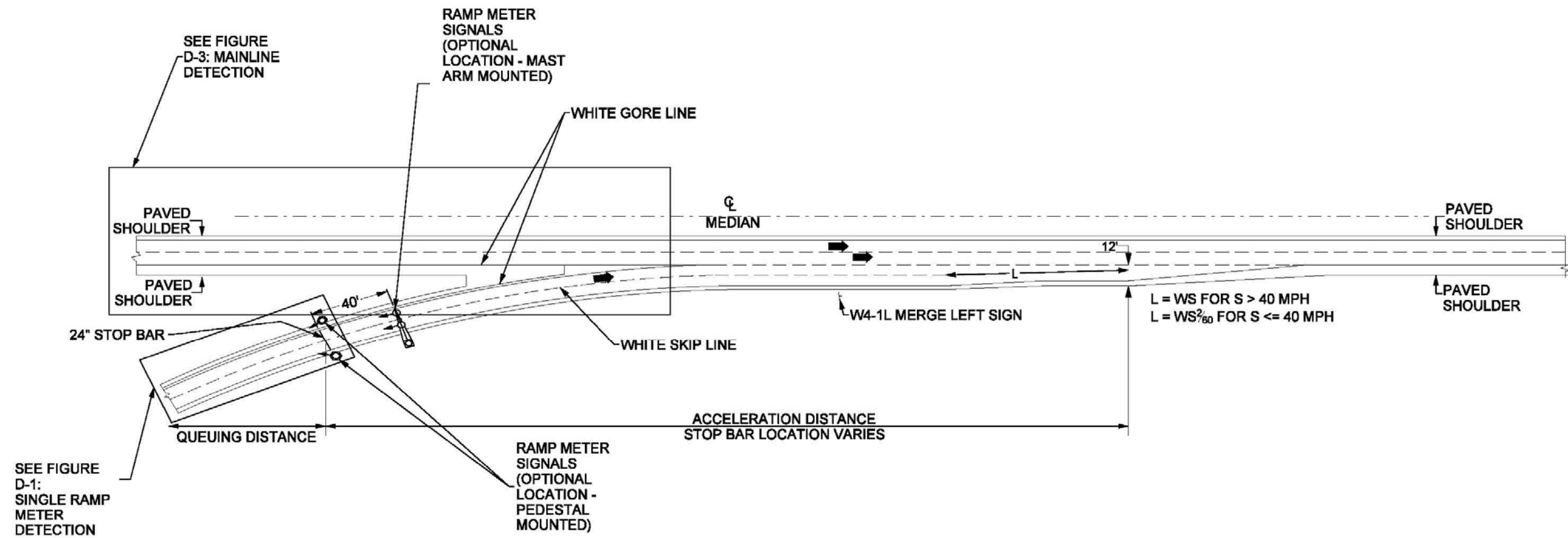

Notes

1. When truck volumes exceed 5% on 3% or greater ascending grades, provide 500' of auxiliary lane between the ramp meter stop bar and point where the ramp and mainline edges of pavement are 10' apart.
2. See AASHTO Exhibit 3-1 for acceleration distances.
3. Signal heads may be pedestal mounted or mast arm mounted as site conditions dictate for two-lane applications.
4. Install W4-1L, merge left sign, in accordance with Table 2C-54 of the MUTCD.
5. See Figure C-1 for signalization and equipment.
6. See Figure D-1 for ramp meter detection.
7. See Figure D-3 for mainline detection.
8. See Figure E-1 for ramp meter signing and pavement markings.

Figure B-2: Two Lane Ramp Meter Overview

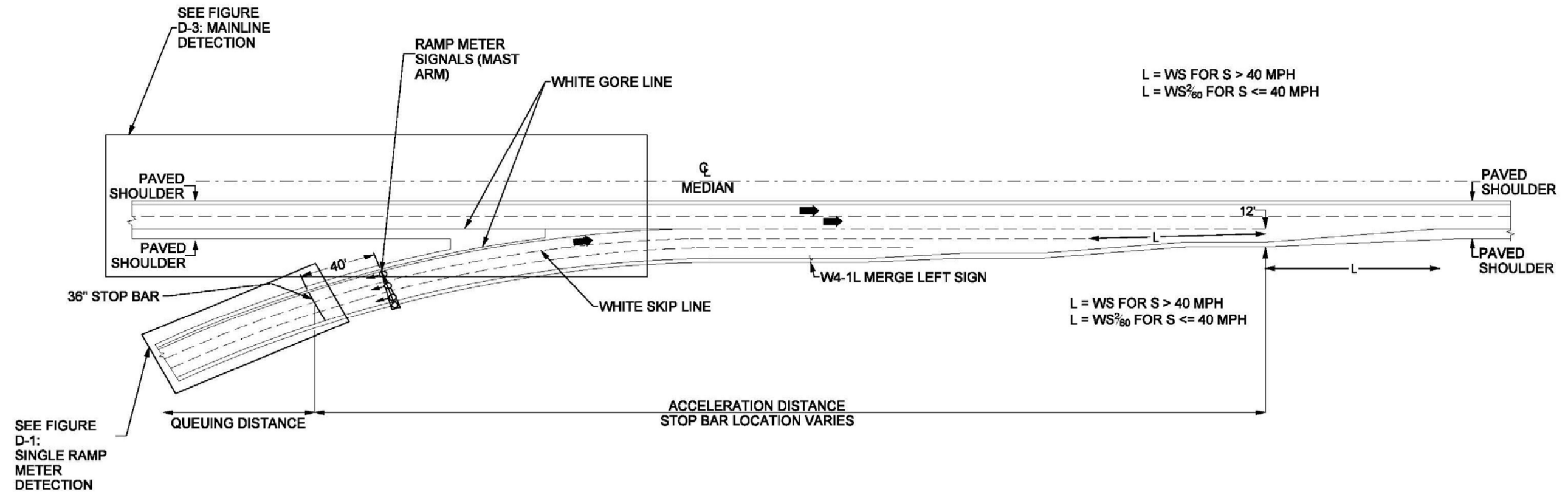

Notes

1. When truck volumes exceed 5% on 3% or greater ascending grades, provide 500' of auxiliary lane between the ramp meter stop bar and point where the ramp and mainline edges of pavement are 10' apart.
2. See AASHTO Exhibit 3-1 for acceleration distances.
3. Signal heads shall be mast arm mounted as site conditions dictate for three or more lanes.
4. Install W4-1L, merge left sign, in accordance with Table 2C-54 of the MUTCD.
5. See Figure C-3 for signalization and equipment.
6. See Figure D-1 for ramp meter detection.
7. See Figure D-3 for mainline detection.
8. See Figure E-1 and E-3 for ramp meter signing and pavement markings.

Figure B-3: Three Lane Ramp Meter Overview

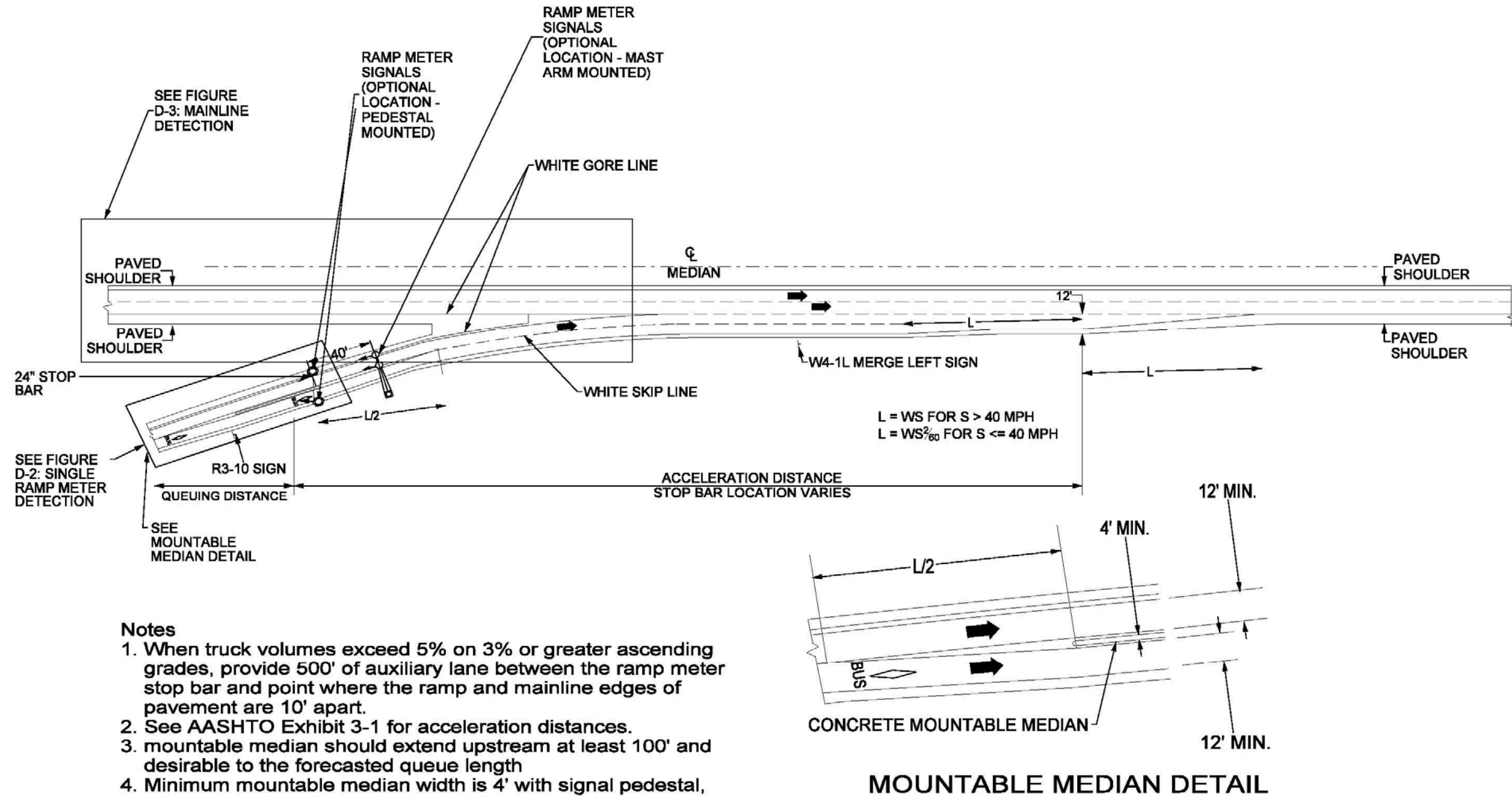

Notes

1. When truck volumes exceed 5% on 3% or greater ascending grades, provide 500' of auxiliary lane between the ramp meter stop bar and point where the ramp and mainline edges of pavement are 10' apart.
2. See AASHTO Exhibit 3-1 for acceleration distances.
3. mountable median should extend upstream at least 100' and desirable to the forecasted queue length
4. Minimum mountable median width is 4' with signal pedestal, minimum width is 2' without pedestal.
5. Signal heads may be pedestal mounted or mast arm mounted as site conditions dictate.
6. Install W4-1L, merge left sign, in accordance with Table 2C-54 of the MUTCD.
7. See Figure C-1 for signalization and equipment.
8. See Figure D-2 for ramp meter detection.
9. See Figure D-3 for mainline detection.
10. See Figure E-1 for ramp meter signaling and pavement markings.

Figure B-4: Single Lane Ramp Meter with Transit Bypass Overview

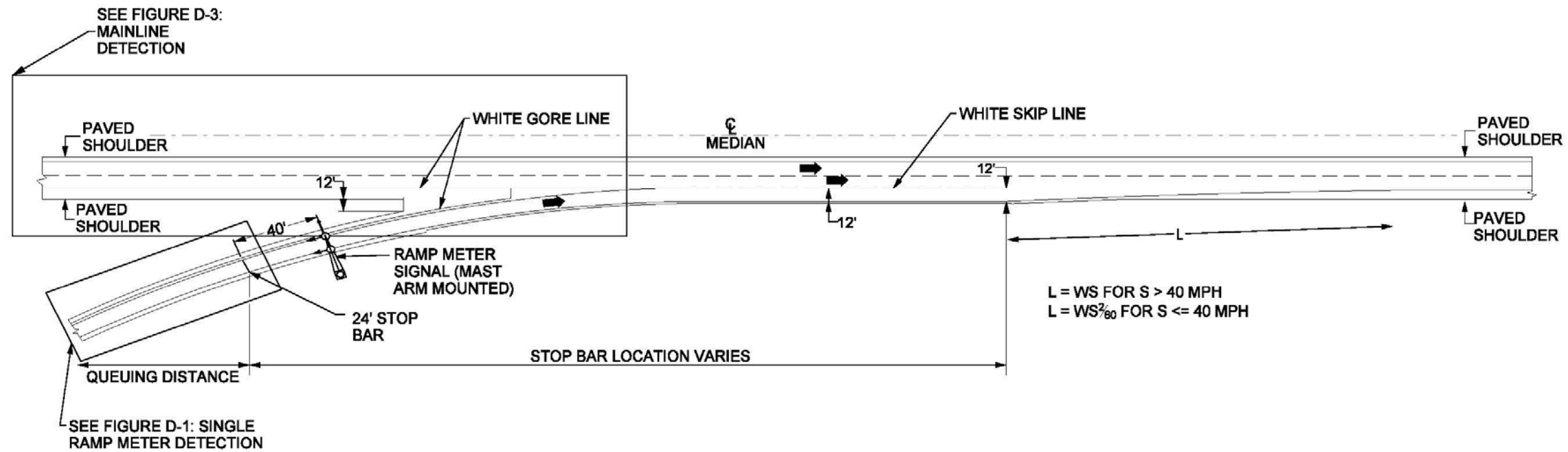

Notes

1. When truck volumes exceed 5% on 3% or greater ascending grades, provide 500' of auxiliary lane between the ramp meter stop bar and point where the ramp and mainline edges of pavement are 10' apart.
2. See AASHTO Exhibit 3-1 for acceleration distances.
3. Signal heads shall be mast arm mounted as site conditions dictate.
4. See Figure C-1 for signalization and equipment.
5. See Figure D-1 for ramp meter detection.
6. See Figure D-3 for mainline detection.
7. See Figures E-1 and E-3 for ramp meter signing and pavement markings.

Figure B-5: Single Lane Freeway-to-Freeway Ramp Meter Overview

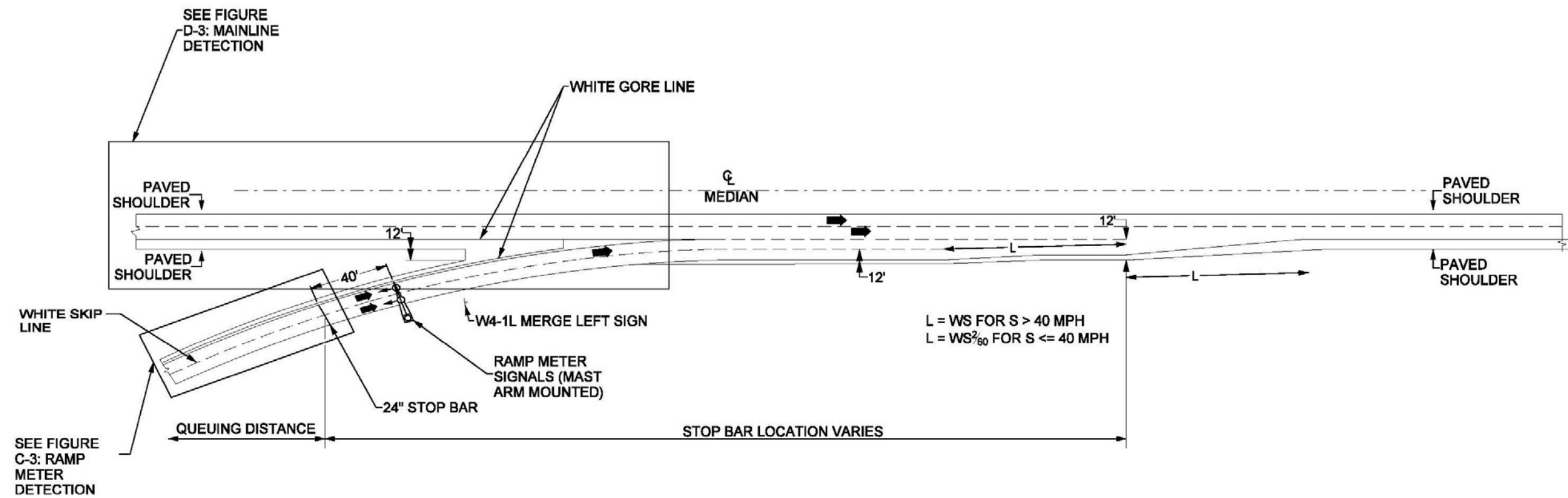

Notes

1. When truck volumes exceed 5% on 3% or greater ascending grades, provide 500' of auxiliary lane between the ramp meter stop bar and point where the ramp and mainline edges of pavement are 10' apart.
2. See AASHTO Exhibit 3-1 for acceleration distances.
3. Signal heads shall be mast arm mounted as site conditions dictate.
4. Install W4-1L, merge left sign, in accordance with Table 2C-54 of the MUTCD.
5. See Figure C-3 for signalization and equipment.
6. See Figure D-1 for ramp meter detection.
7. See Figure D-3 for mainline detection.
8. See Figures E-1 and E-3 for ramp meter signing and pavement markings.

Figure B-6: Two Lane Freeway-to-Freeway Ramp Meter Overview

Appendix C. Signal Head and Equipment Layouts

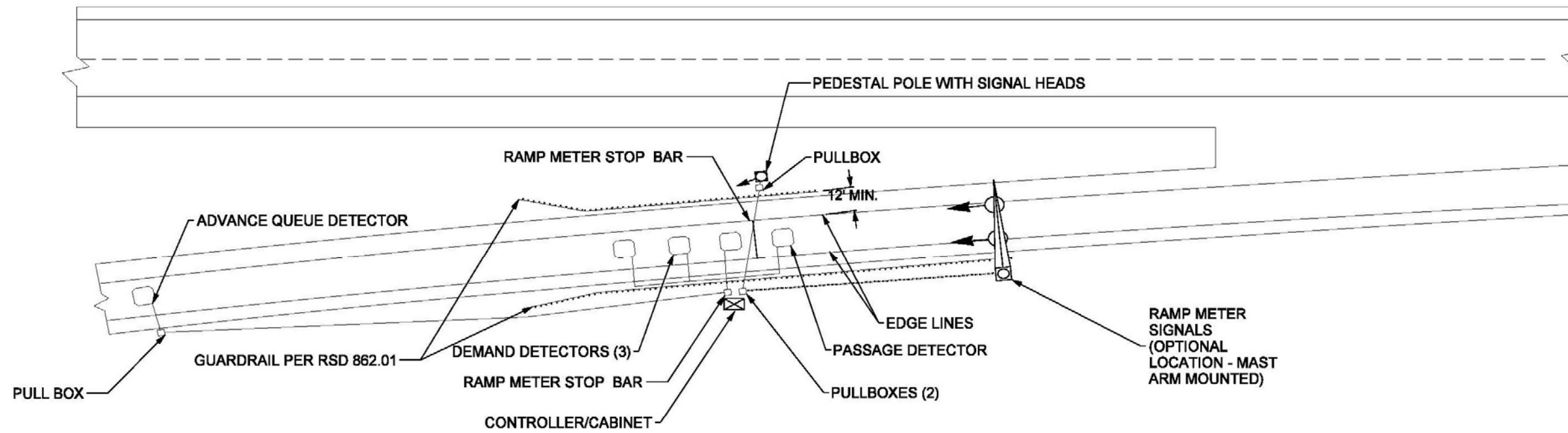

Notes

1. Use pedestal mounted signals only for single lane non-freeway to freeway ramp locations. Locate pedestal mounted signals to the left of the ramp and pointed towards the stop bar to minimize view from the mainline.
2. Use mast arm mounted signals only for freeway to freeway ramp locations.
3. Mast arm supports and controller cabinet may be on either side of ramp as site conditions dictate.
4. Use breakaway pedestal poles when guardrail is not existing or otherwise installed.
5. Protect signal cabinet and mast arm supports with guardrail or setback distance in accordance with clear zone standards.

Figure C-1: Single Lane Ramp Meter Signalization and Equipment Layout

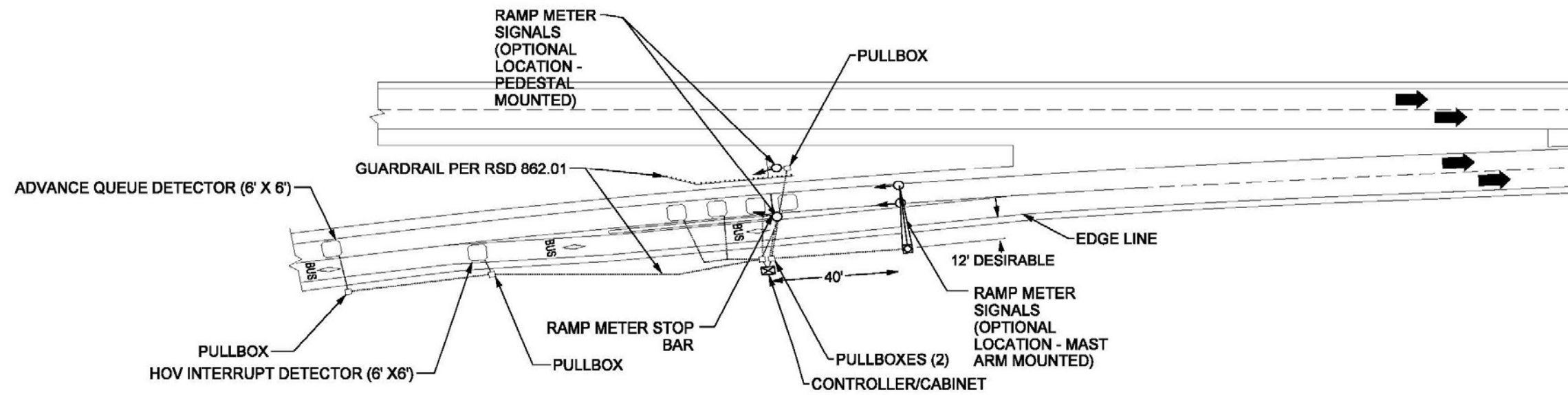

Notes

1. Use pedestal mounted signals only for single lane non-freeway to freeway ramp locations.
2. Locate pedestal mounted signals to the left of the ramp and pointed towards the stop bar to minimize view from the mainline.
3. Protect signal pedestal and cabinet with guardrail or setback distance in accordance with clear zone standards.
4. Use breakaway pedestal poles when guardrail is not existing or otherwise installed.
5. Protect signal cabinet and mast arm supports with guardrail or setback distance in accordance with clear zone standards.

Figure C-2: Single Lane Ramp Meter with Transit Bypass Signalization and Equipment Layout

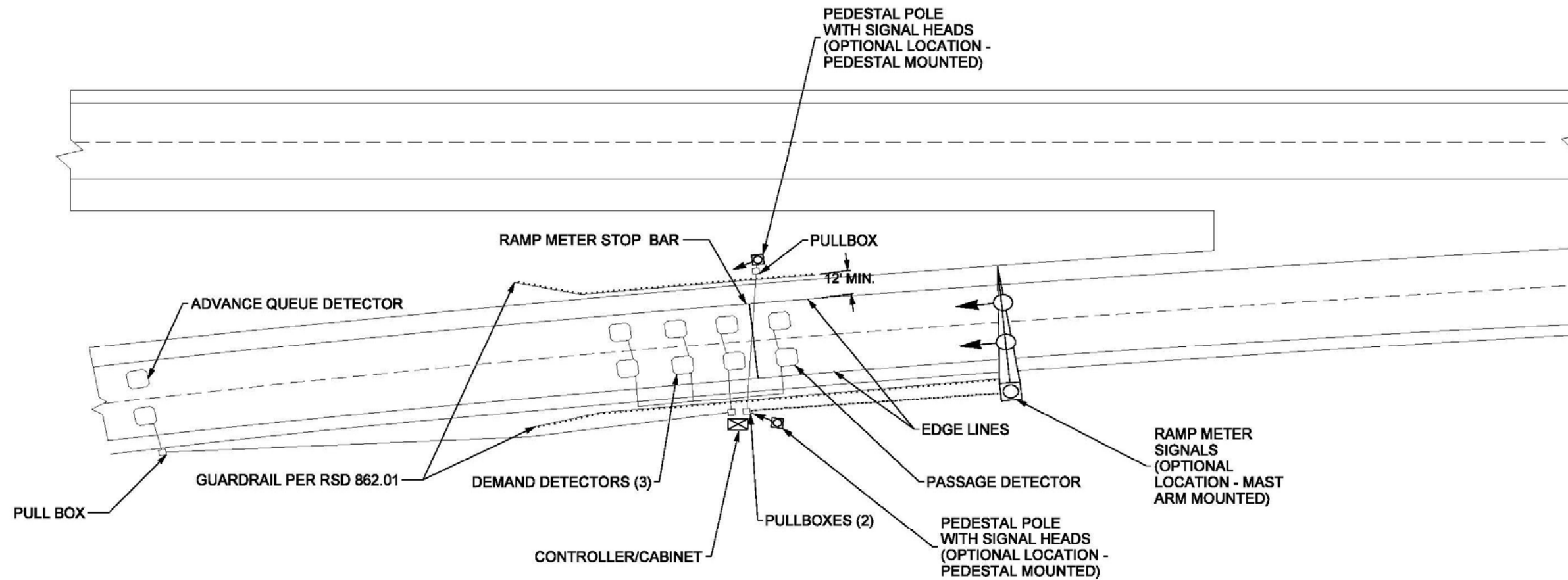

Notes

1. Use pedestal mounted signals for single and two lane non-freeway to freeway ramp locations. Locate pedestal mounted signals to the left of the ramp and pointed towards the stop bar to minimize view from the mainline.
2. Use mast arm mounted signals only for two lane or freeway to freeway ramp locations.
3. Mast arm supports and controller cabinet may be on either side of ramp as site conditions dictate.
4. Use breakaway pedestal poles when guardrail is not existing or otherwise installed.
5. Protect signal cabinet and mast arm supports with guardrail or setback distance in accordance with clear zone standards.

Figure C-3: Two Lane non-Freeway-to-Freeway Ramp Meter Signalization and Equipment Layout

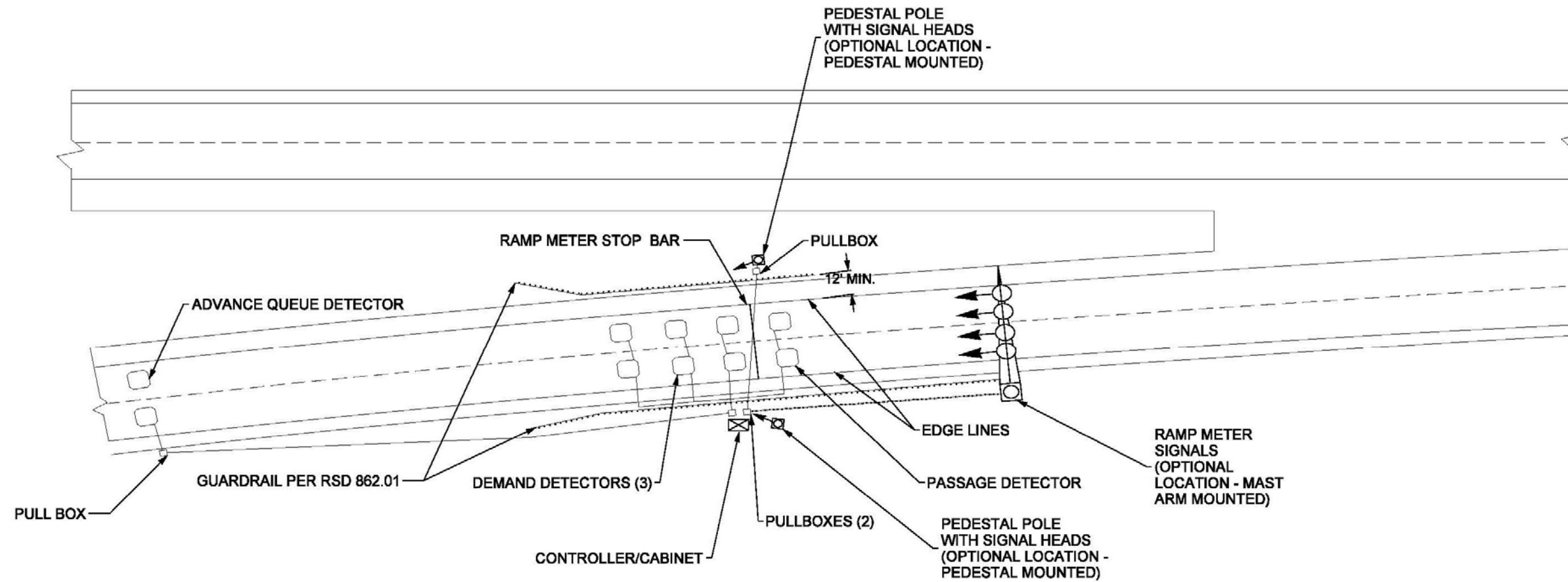

Notes

1. Use pedestal mounted signals for single and two lane non-freeway to freeway ramp locations. Locate pedestal mounted signals to the left of the ramp and pointed towards the stop bar to minimize view from the mainline.
2. Use mast arm mounted signals only for two lane or freeway to freeway ramp locations.
3. Mast arm supports and controller cabinet may be on either side of ramp as site conditions dictate.
4. Use breakaway pedestal poles when guardrail is not existing or otherwise installed.
5. Protect signal cabinet and mast arm supports with guardrail or setback distance in accordance with clear zone standards.

Figure C-4: Freeway-to-Freeway Ramp Meter Signalization and Equipment Layout

Appendix D. Ramp and Mainline Detection Layouts

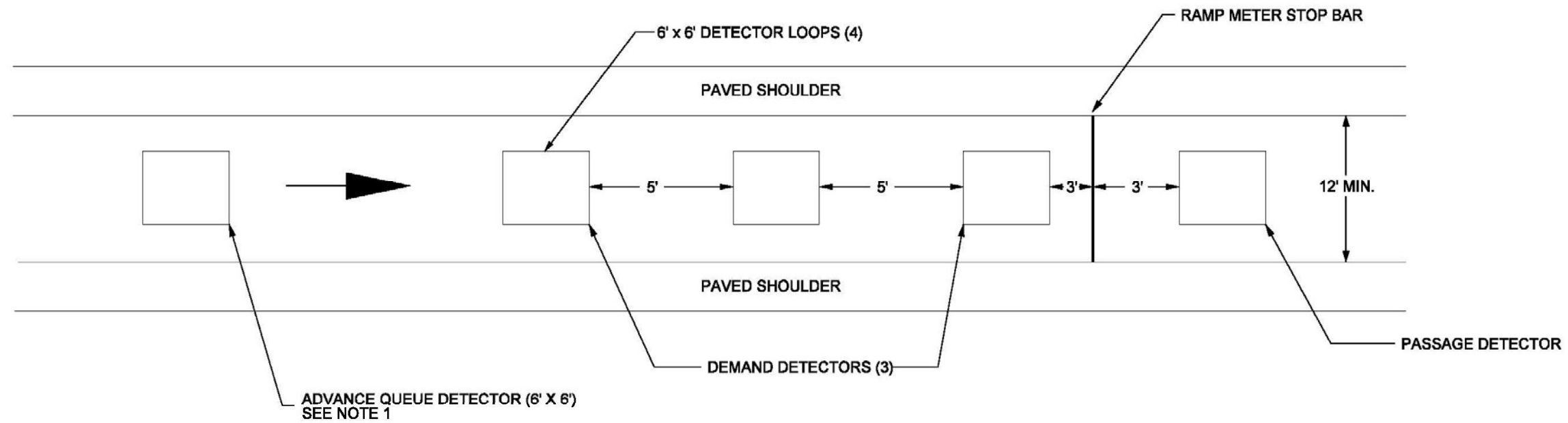

Notes

1. Place advance queue detector upstream of predicted queue per Table 4 but no more than 300 feet from the surface street intersection.
2. For dual lane ramp meter place detectors in second lane at same longitudinal spacing.
3. See Figure D-3 for mainline detection.

Figure D-1: Single Lane Ramp Meter Detection

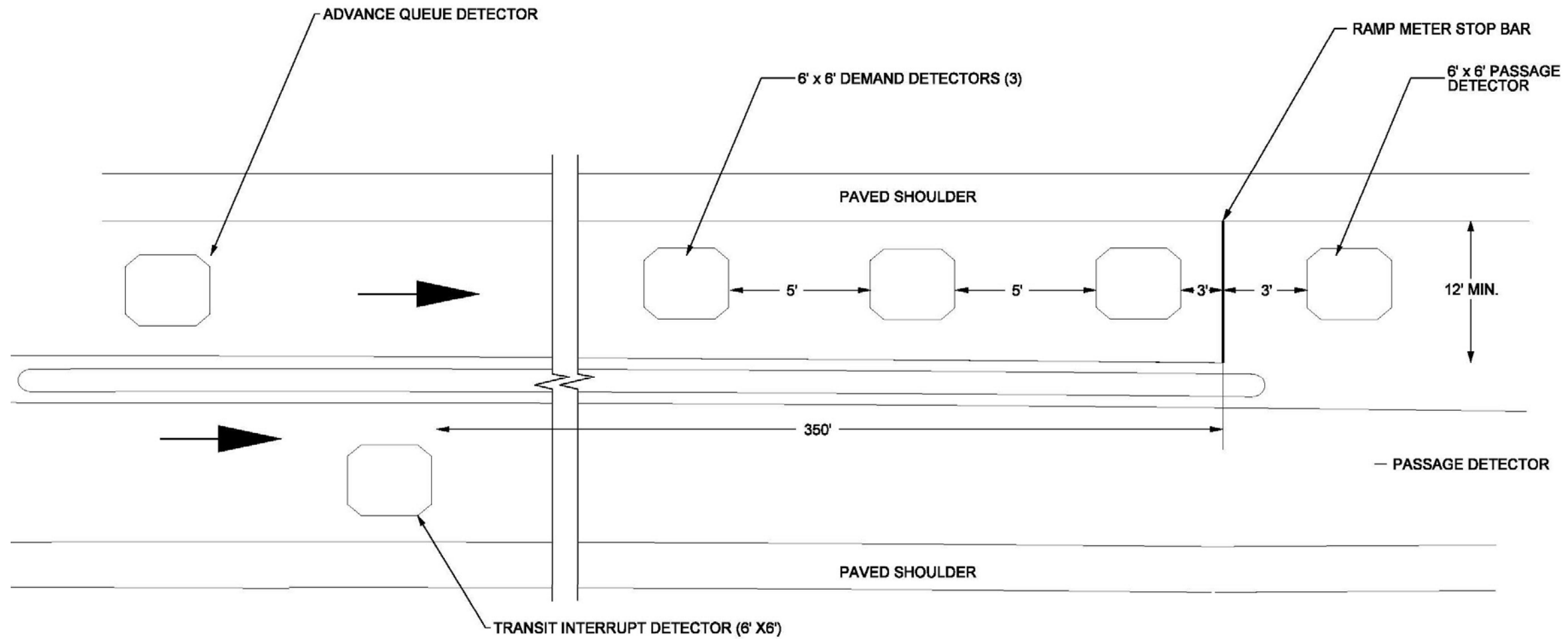

Notes

1. Place advance queue detector upstream of predicted queue per Table 4 but no more than 300 feet from the surface street intersection.
2. For dual lane ramp meter place detectors in second lane at same longitudinal spacing.
3. See Figure D-3 for mainline detection.

Figure D-2: Single Lane Ramp Meter with Transit Bypass Detection

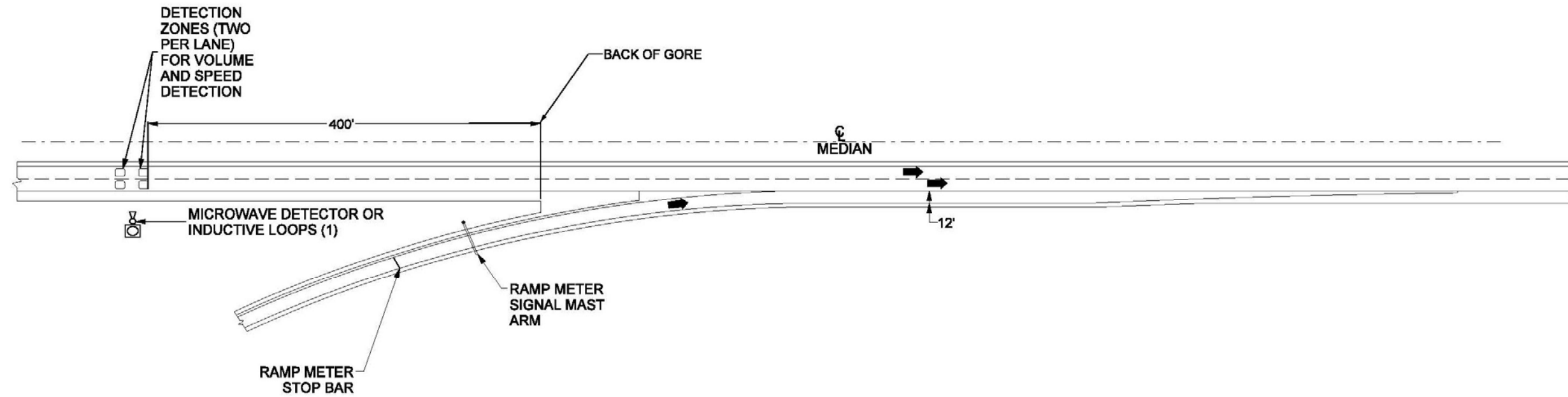

Notes

1. See Figures D-1 and D-2 ramp meter detection.
2. Install microwave detector(s) according to manufacturer's recommendations to avoid signal distortion due to bridges, sign structures, walls and barriers.
3. Adjust detector location as required by site conditions.

Figure D-3: Mainline Detection

Appendix E. Typical Ramp Meter Signing Layouts

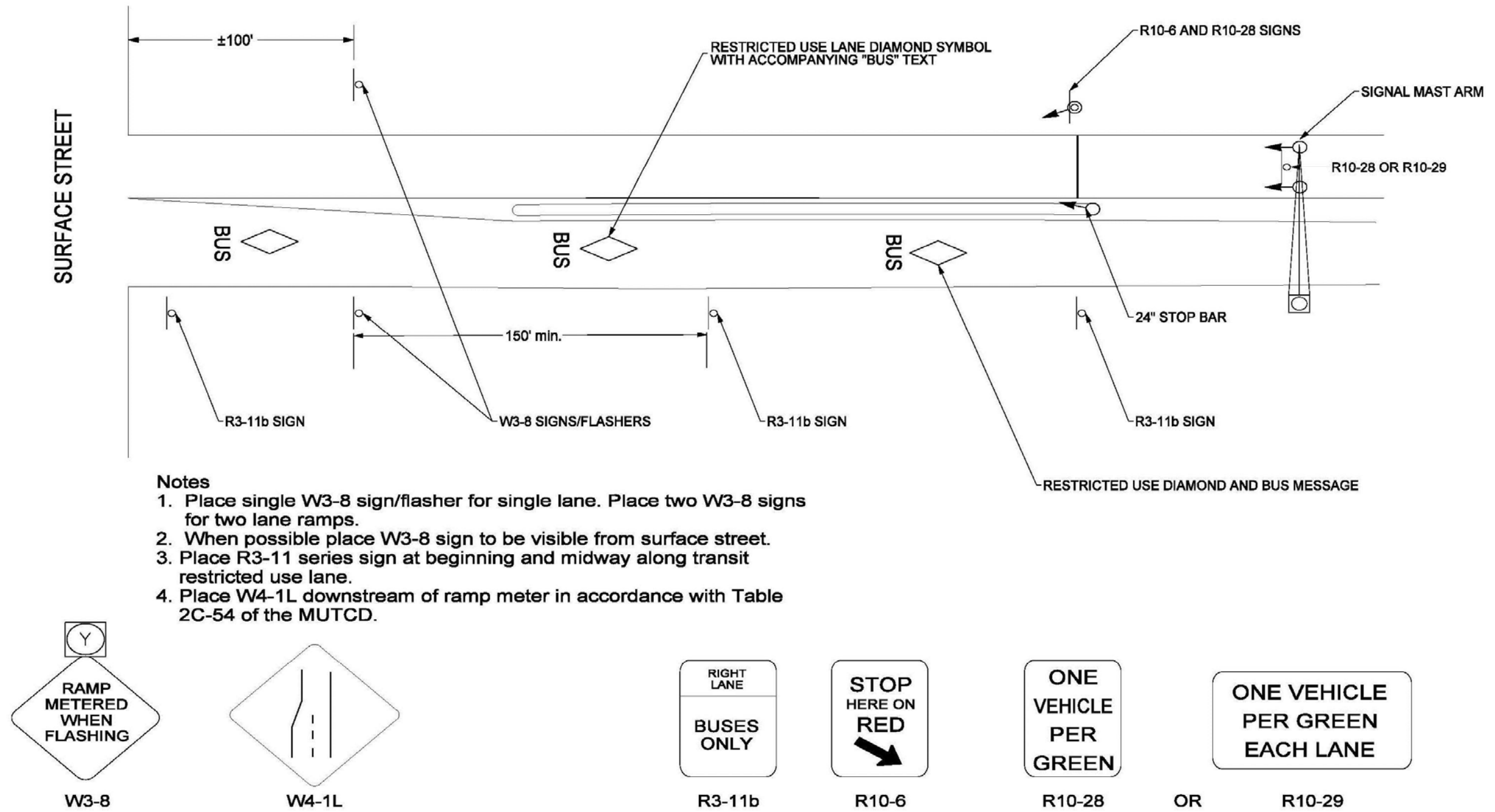
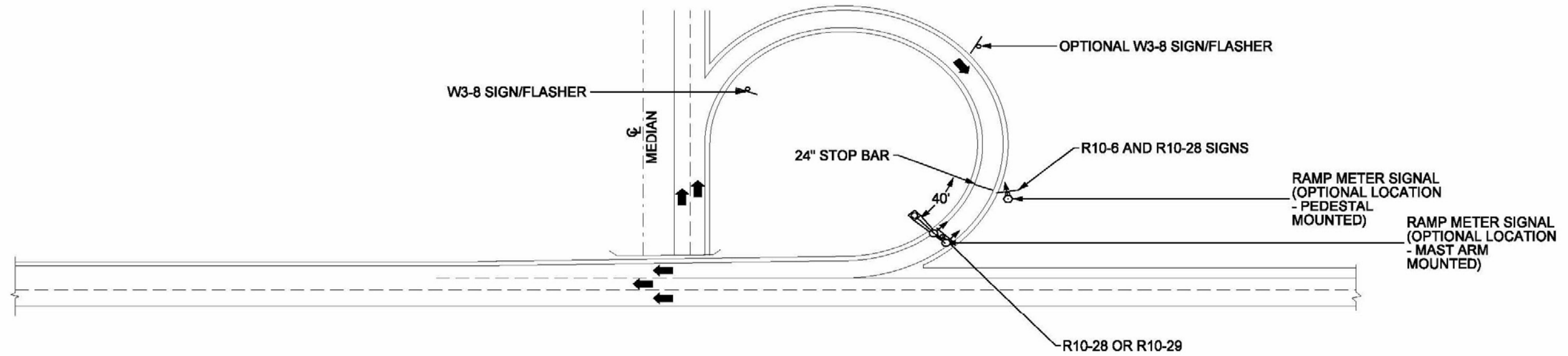

Figure E-1: Non-Freeway-to-Freeway Ramp Meter Signing and Pavement Markings



Notes

1. When truck volumes exceed 5% on 3% or greater ascending grades, provide 1000' of auxiliary lane between the ramp meter stop bar and point where the ramp and mainline edges of pavement are 10' apart.
2. Install additional W3-8 sign and flasher as necessary for locations where sight distance is limited.

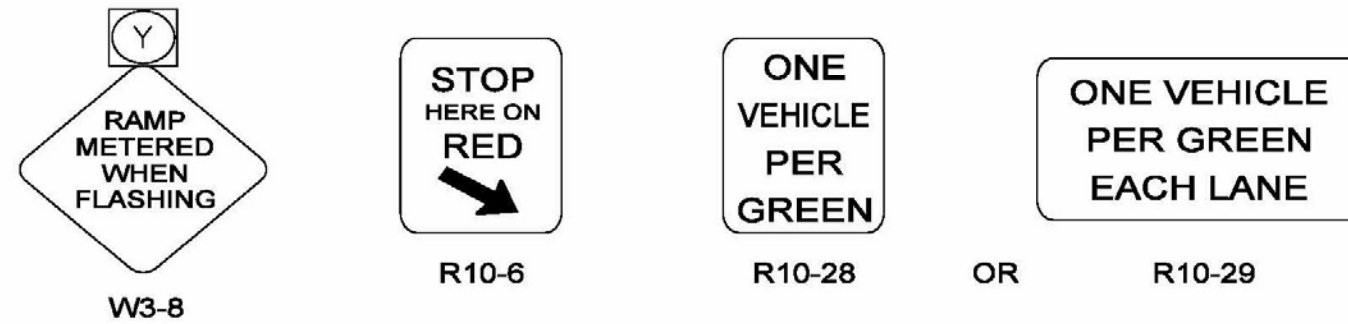
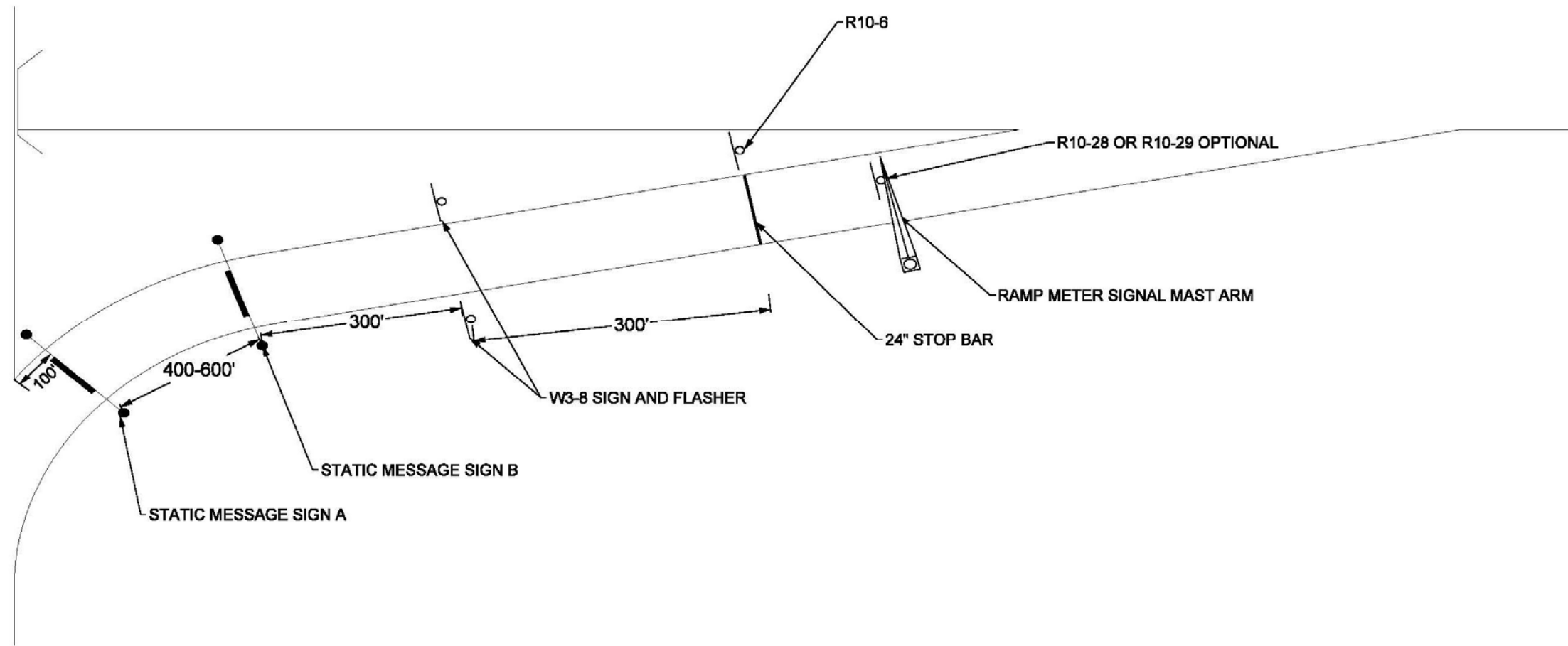

Figure E-2: Single Lane Loop Ramp Meter Signing and Pavement Markings



- Notes**
1. See Figure E-2 for additional sign details.
 2. Place single W3-8 sign/flasher for single lane. Place two W3-8 signs/flashers for two lane ramps.
 3. When possible place W3-8 sign to be visible from surface street.

STATIC SIGN MESSAGE A



STATIC SIGN MESSAGE B



Figure E-3: Freeway-to-Freeway Ramp Meter Signing and Pavement Markings

Appendix F. Optional Enforcement Features

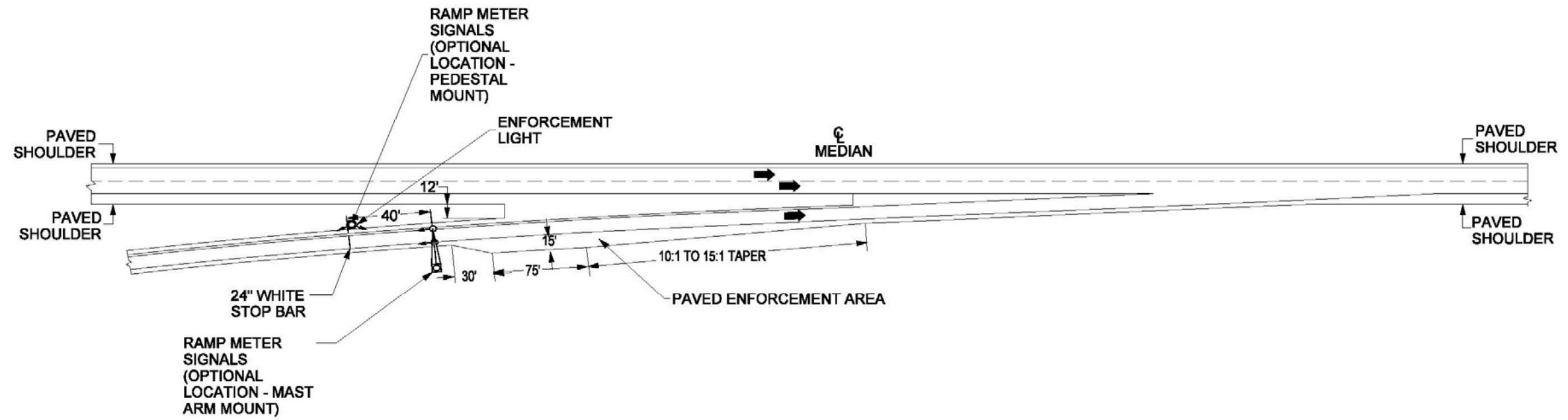

- Notes**
1. Begin taper to enforcement area 0-75' downstream of stop bar.
 2. Dimensions may be adjusted to fit site conditions.
 3. Enforcement areas are suitable locations having two metered lanes or one lane metered and one transit bypass lane.

Figure F-1: Optional Enforcement Features

Alf Badgett, PE

Atkins

5200 Seventy Seven Center Drive, Suite 500
Charlotte, NC 28217

Alf.badgett@atkinsglobal.com

704.665.4403

© Atkins Ltd except where stated otherwise.

The Atkins logo, 'Carbon Critical Design' and the strapline
'Plan Design Enable' are trademarks of Atkins Ltd.